

# Compact-Line



GB Translation of the original operating Instructions



cBoxX 30  
cBoxX 40  
cBoxX 50  
cBoxX 60  
cBoxX 70  
cBoxX 80  
cBoxX 90  
cBoxX 100  
cBoxX 120  
cBoxX 160  
cBoxX 180  
cBoxX 200

**Table 1: Contact details**

<p>Manufacturer</p>	<p>ait-deutschland GmbH          Industriestraße 3          95359 Kasendorf          Germany          T +49 9228 9977 0          F +49 9228 9977 149          E <a href="mailto:info@kkt-chillers.com">info@kkt-chillers.com</a>          W <a href="http://www.kkt-chillers.com">www.kkt-chillers.com</a></p>
<p>Service</p>	<p>ait-deutschland GmbH          Industriestraße 3          95359 Kasendorf          Germany          T +49 9228 9977 7190 *          F +49 9228 9977 7474          E <a href="mailto:service@kkt-chillers.com">service@kkt-chillers.com</a>          W <a href="http://www.kkt-chillers.com">www.kkt-chillers.com</a>*</p> 
<p>Service USA</p>	<p>KKT chillers, Inc.          1280 Landmeier Road          Elk Grove Village          IL 60007          T +1 833 558 4357          F +1 847 734 1601          TF +1 866 517 6867 *          E <a href="mailto:support@kkt-chillersusa.com">support@kkt-chillersusa.com</a></p> 

## Introduction

These operating instructions have been drawn up by KKT chillers on the basis of the Machinery Directive 2006/42/EC. They contain all important information and instructions for the installation and safe operation of the refrigerating machine (chiller). It also contains advice on how to prevent or correct faults.

Please allow yourself sufficient time to read through these instructions carefully and to digest all the information this document contains. If you have any further questions, please contact the KKT chillers Service Team using the contact details provided.

If properly used for its intended use and correctly maintained, the chiller ensures sustained, fault-free operation. The methods and procedures described in these instructions should help you to detect problems early and to take appropriate countermeasures.

If you keep to the maintenance programme described you ensure the reliability and safety of the machine. You also keep the operating costs low and at the same time increase the life of the components.

To ensure that the performance of your chiller is not impaired, we recommend that you only use original spare parts purchased from KKT chillers. In this way you ensure the reliability and quality of the machine.

	<p><b>ATTENTION! A black exclamation mark on a yellow background in a triangle indicates important information and instructions to which you must pay particular attention and must always follow.</b></p>
---	--

KKT chillers reserves the right to change technical details without prior notice. The illustrations in this document are not to scale!

As the Compact-Line units can be adapted to specific projects, this document only contains information that is generally valid for all units in the series.

All project-specific data is enclosed with the unit in separate summary documentation.

- Machine configuration
- Parameter list
- P&I diagram
- Pump characteristic curve(s)
- Circuit diagram
- All other project specific details

## Contents

Introduction.....	3
1. Product description .....	8
1.1. Intended use .....	8
1.2. Elements.....	11
1.3. Explanation of terms.....	12
2. Function and main components.....	13
2.1. Compressor .....	13
2.2. Evaporator .....	14
2.3. Condenser .....	14
2.4. Expansion valve .....	14
2.5. Refrigerant.....	14
2.6. Oil.....	15
2.7. Filter dryer .....	15
2.8. Pressure sensors .....	15
2.9. Temperature sensors.....	15
2.10. Control unit/ main circuit board.....	15
2.11. Display .....	15
2.12. Control cabinet.....	15
2.13. Pump.....	16
2.14. Fan .....	16
2.15. Cold water cycle .....	16
2.16. Materials used in the water circuit .....	17
2.17. Water quality .....	19
2.18. Permitted cooling media .....	19
3. Options and accessories .....	20
3.1. Version without tank, with pump .....	20
3.2. Version without tank, without pump.....	20
3.3. Version with water cooled condenser.....	20
3.4. Heater for compressor and control cabinet .....	21
3.5. Insulation of the cold pipes and the pump(s) .....	21
3.6. Tank heater with thermostatic pump start.....	21
3.7. Overflow valve for standby mode.....	22
3.8. Higher pressure pump .....	22
3.9. Second consumer circuit.....	22
3.10. Additional evaporator pump.....	23
3.11. Frequency controlled pump .....	23
3.12. Automatic water feed.....	23
3.13. Water circuit in non-ferrous metal-free version .....	24
3.14. DI package.....	24
3.15. Special voltage .....	24
3.16. Phase monitoring.....	24
3.17. Hot gas bypass for output control <1K.....	24
3.18. High-temperature package.....	24

3.19.	Special paint finish .....	24
3.20.	Air filter mat (accessories).....	25
3.21.	Levelling feet (accessories).....	25
3.22.	Level package (accessories) .....	25
3.23.	Filter assembly group coolant circuit (accessories).....	26
3.24.	Filter assembly group cooling water circuit (accessories).....	26
3.25.	MultiplexX connection group (accessories).....	26
3.26.	Refill cartridge R410A (accessories) .....	26
3.27.	Anybus-Gateway (accessories).....	26
3.28.	Remote Control Panel (accessories).....	27
3.29.	Special languages (accessories).....	27
3.30.	Wooden Crate (accessories) .....	27
3.31.	Seaworthy crate packaging (accessories) .....	27
3.32.	Water Pump Redundancy.....	27
3.33.	Closed Water Loop.....	28
3.34.	Energy meter .....	28
4.	Safety.....	29
4.1.	General information.....	29
4.2.	Hazard warnings .....	29
4.3.	Residual energy.....	32
4.4.	Safety devices, guards and safeguards .....	33
4.4.1.	High-pressure limiter.....	33
4.4.2.	High-pressure monitoring .....	34
4.4.3.	Low-pressure monitoring .....	34
4.4.4.	Flow monitoring.....	34
4.4.5.	Personal protective equipment when operating the machine .....	34
4.5.	Personal protective equipment for servicing work .....	35
4.6.	Airborne sound emissions.....	35
4.7.	Notes on reducing noise and vibration.....	36
4.7.1.	Noise .....	36
4.7.2.	Vibration.....	36
4.8.	Residual risks.....	37
4.8.1.	Electrical .....	37
4.8.2.	Mechanical .....	37
4.8.3.	Chemical .....	37
4.8.4.	Other .....	37
4.9.	Dangerous substances.....	38
4.9.1.	Refrigerant R410A .....	38
4.9.2.	Oil POE 160SZ.....	39
4.10.	Reasonably foreseeable misuse.....	40
4.11.	Information for emergencies.....	41
5.	Handling and storage .....	41
5.1.	Dangerous goods.....	41
5.2.	Transport .....	41
5.2.1.	Forklift truck .....	42

5.2.2.	Crane.....	43
5.3.	Unpacking.....	44
5.4.	Storage .....	45
6.	Installation .....	46
6.1.	Overview .....	46
6.2.	Installation site.....	46
6.2.1.	General information .....	46
6.2.2.	Minimum room volume.....	46
6.2.3.	Ambient temperature.....	47
6.2.4.	Effect of surrounding air flow .....	47
6.2.5.	Minimum clearances .....	47
6.2.6.	Process level.....	47
6.2.7.	Surface and foundation .....	48
6.2.8.	Stability .....	48
6.2.9.	Levelling.....	48
6.2.10.	Vibration isolation .....	48
6.2.11.	Installation.....	49
6.2.12.	Hydraulic installation .....	50
6.2.13.	Frost protection measures .....	51
6.2.14.	Flushing the cold water circuit .....	51
6.2.15.	Filling.....	51
6.2.16.	Venting.....	53
6.2.17.	Electrical installation.....	54
7.	Commissioning .....	56
7.1.	Installation checklist.....	56
8.	Operation.....	57
8.1.	Switching on .....	57
8.2.	Selecting the operating mode .....	57
8.3.	External release .....	57
8.4.	Control .....	57
8.5.	Control panel.....	58
8.5.1.	Start screen .....	59
8.5.2.	Main menu.....	60
8.5.3.	Information .....	60
8.5.4.	Settings.....	62
8.5.5.	Alarm menu .....	63
8.6.	Parameters.....	63
8.7.	Controller description .....	64
8.7.1.	Thermostatic pump start .....	64
8.7.2.	Electronic level monitoring .....	64
8.7.3.	Switching the chiller On/off .....	65
8.7.4.	Cold water flow temperature control .....	66
8.7.5.	Compressor control.....	66
8.7.6.	Fan speed control .....	67
8.7.7.	Electronic expansion valve control.....	67

8.7.8.	Temperature limit monitoring.....	67
8.7.9.	Group fault alarm .....	67
8.1.	Execution types .....	68
8.1.1.	ECO mode .....	68
8.1.2.	Comfort mode.....	68
9.	Cleaning .....	69
9.1.	Air filter mat.....	69
9.2.	Condenser .....	69
9.3.	Water filter.....	69
9.4.	Complete cleaning of the cold water circuit.....	69
10.	Service.....	70
10.1.	Maintenance .....	70
10.2.	Fault correction .....	70
10.3.	Spare parts.....	70
11.	Taking out of service .....	71
11.1.	Draining .....	71
12.	Recycling .....	72
13.	Products, solutions and services.....	72
I.	Main dimensions .....	73
II.	Installation instructions.....	77
III.	Menu navigation .....	81
IV.	Troubleshooting.....	94
V.	Maintenance intervals in accordance with the VDMA.....	106
VI.	Product Registration.....	109
VII.	EC Declaration of Conformity .....	110

## 1. Product description

Please read all the points in these operating instructions before starting up the machine. You should pay particular attention to the points on safety, commissioning/startup and operation. If you have further questions about your machine, please contact the KKT chillers Service Team (**see Table 1: Contact details**).

### 1.1. Intended use



The cBoxX is a factory-tested, fully automatic compressor chiller. The machine is solely for cooling liquids (fluids) in accordance with EN 378-1. An adequate supply of cooling air must be provided. Only approved liquids may be used. The cBoxX corresponds to protection class IP 54 (when the housing is closed) and is suitable for both indoor and outdoor installation (note the options packages).

The operator is responsible for complying with the specified operating, servicing and maintenance conditions according to these operating instructions.

The owner of the chiller, not the manufacturer, is responsible and liable for all personal injuries and damage to property caused by improper use of the unit (misuse).

Table 2 shows the general safety instructions of the chiller. These are attached to the machine in a clear and readily visible position. A complete description of all hazard warnings is given in Chapter **4.2 Hazard warnings**.

Table 2: Safety instructions

	Note and follow the instructions for use!
	Before opening the machine it must be disconnected from the power supply! After disconnecting the machine from the power supply, always wait for at least 5 minutes before opening it.
	Danger! High voltage! If the machine is only switched off at its main switch, dangerous electrical voltage is still present at several terminals in the control cabinet.



Technical data

Table 3: Technical data

Compact-Line	-	cBoxX 30	cBoxX 40	cBoxX 50	cBoxX 60	cBoxX 70	cBoxX 80	cBoxX 90	cBoxX 100
Refrigerating capacity @ tw2=20°C / tu=32°C	kW	34	41	53	67	76	83	92	100
Refrigeration circuit hermetically tight		no							
Refrigerant	-	R410A							
GWP		2088							
Refrigerant capacity	kg	6	6	6	7	8	8	8	8
CO2 equivalent	t CO2	12,5	12,5	12,5	14,6	16,7	16,7	16,7	16,7
Cooling medium (liquid/secondary refrigerant)	-	Water or water / glycol							
Ambient temperature range	°C	+5 to +45 (optionally -25 to +50°C)							
Liquid feed temperature	°C	+8 to +30 (optionally to -10)							
Target constancy	K	+/-1							
Tank volume	l	300				500			
Coolant circulation, nominal (dt = 5K)	m³/h	5.5	7.2	9.2	11.1	12.4	14.3	16.1	18.2
Free pump pressure (standard)	bar	3							
Water connection, nominal size	RP	1 1/2"				2"			
Air flow rate (max.)	m³/h	9350	9350	12600	20000	23270	23270	23270	23270
Sound pressure level at 5 m distance	dBA	62	62	55	69	59	59	59	59
Operating voltage (standard)	V/Ph/Hz	400/ 3/ 50 (±10%)							
Protection class	-	IP54							
Height	mm	2030				2030			
Width	mm	830				830			
Length	mm	1240				1840			
Net weight	kg	540	540	550	620	650	650	700	720
Gross weight	kg	840	840	850	920	1150	1150	1200	1220

Compact-Line	-	cBoxX 120	cBoxX 160	cBoxX 180	cBoxX 200
Refrigerating capacity @ tw2=20°C / tu=32°C	kW	131	159	187	204
Refrigeration circuit hermetically tight		no			
Refrigerant	-	R410A			
GWP		2088			
Refrigerant capacity	kg	17	17	23,5	23,5
CO2 equivalent	t CO2	35,5	35,5	49,1	49,1
Cooling medium (liquid/secondary refrigerant)	-	Water or water / glycol			
Ambient temperature range	°C	+5 to +45 (optionally -25 to +50°C)			
Liquid feed temperature	°C	+8 to +30 (optionally to -10)			
Target constancy	K	+/-1			
Tank volume	l	700		900	
Coolant circulation, nominal (dt = 5K)	m³/h	21,5	27,2	32,2	35,4
Free pump pressure (standard)	bar	3			
Water connection, nominal size	RP	DN65 PN10 EN1092			
Air flow rate (max.)	m³/h	45550		49100	
Sound pressure level at 5 m distance	dBA	67	67	67	67
Operating voltage (standard)	V/Ph/Hz	400/ 3/ 50 (±10%)			
Protection class	-	IP54			
Height	mm	2030			
Width	mm	1200			
Length	mm	2665		3965	
Net weight	kg	1100	1200	1300	1400
Gross weight	kg	1800	1900	2200	2300

## 1.2. Elements

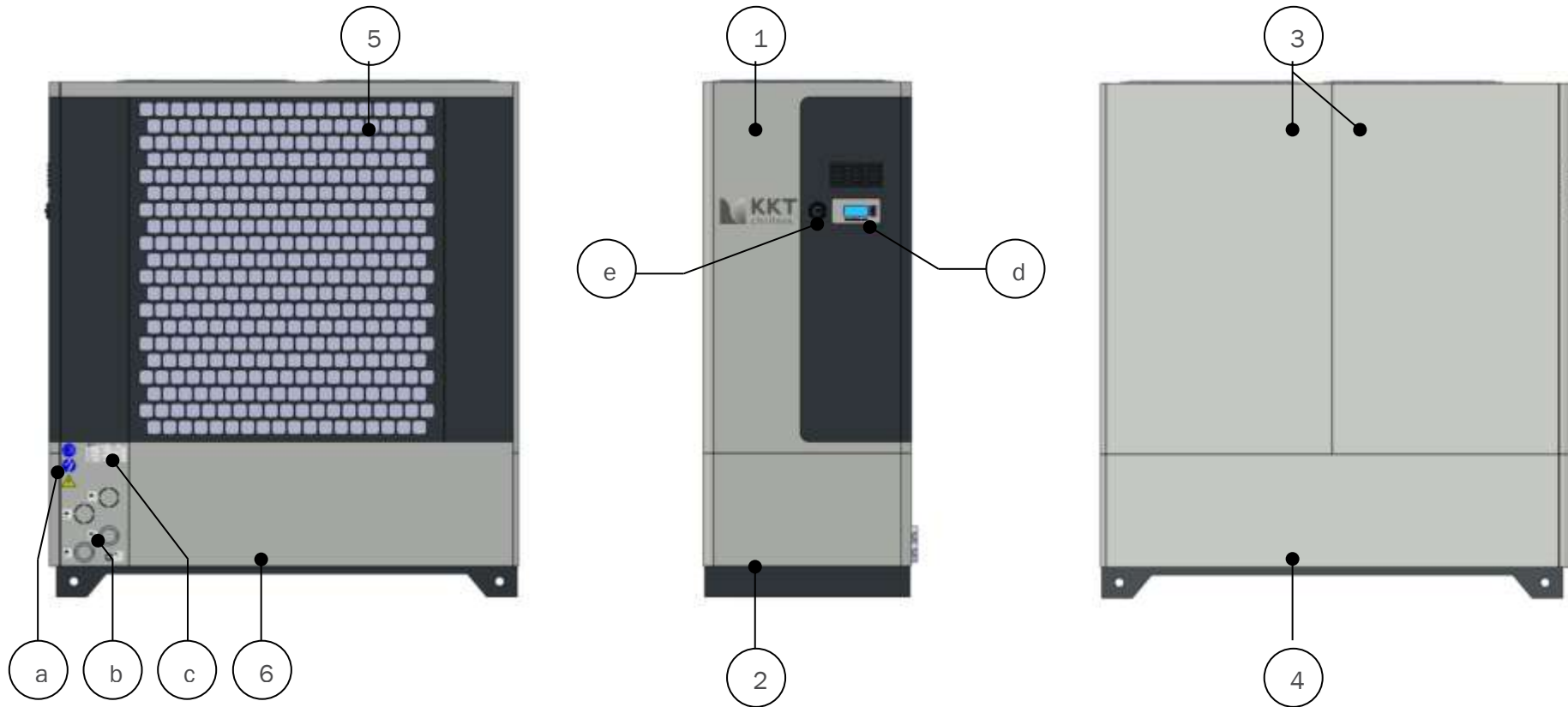

1	Metal cladding, top, operator side		a	Safety instructions
2	Metal cladding, bottom, operator side		b	Water connections
3	Metal cladding, top, service side		c	Rating plate
4	Metal cladding, bottom, service side		d	Display
5	Metal cladding, condenser protective grating		e	Main switch
6	Cladding, hydraulics			

### 1.3. Explanation of terms

A few important terms which appear in this document are briefly explained here for improved understanding.

**Table 4: Explanation of terms**

<b>Term</b>	<b>Explanation</b>
Application	The heat source connected hydraulically with the chiller.
Process circuit	Application and piping to the chiller.
Cold water cycle	The process circuit and chiller in hydraulic piping.
Cold water	Cooling medium in the cold water circuit.
Cooling air	Ambient air drawn through the machine, which absorbs the heat.
Net weight	Ready to operate machine without cold water.
Gross weight	Ready to operate machine including cold water.

## 2. Function and main components

The chiller consists of the main components: compressor, condenser, expansion valve and evaporator, which are arranged in a circuit (**Figure 1**). Refrigerant circulates in this circuit (cycle). It absorbs heat from the cold water in the evaporator and gives it up to the ambient air in the condenser.

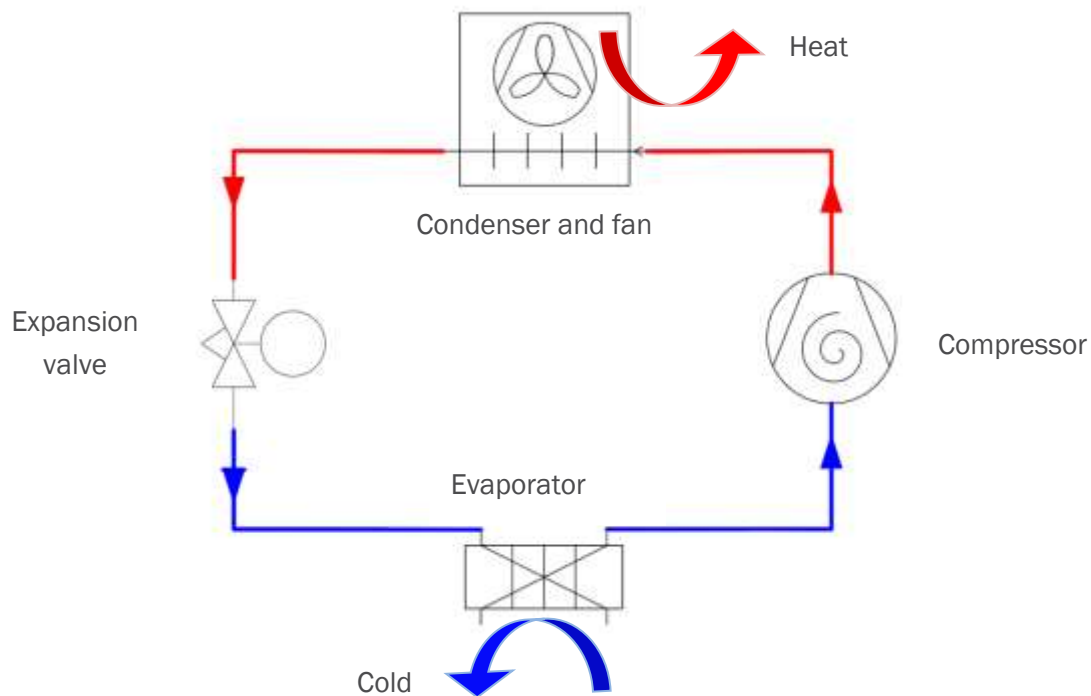

Figure 1: C6848 refrigeration diagram

In addition, diverse pressure and temperature sensors, a control unit, a high-pressure switch, one or more pumps and one or more fans are also installed for control and operation of the chiller.

### 2.1. Compressor

The compressor generates the pressure difference between the heat sink and heat source in the refrigerant circuit needed for evaporation and condensing. Coolant vapor from the evaporator is drawn in and compressed to the condensing pressure in the compressor.

The compressors used operate according to the scroll principle. Scroll compressors are maintenance-free, quiet and have a very high efficiency.

The flow temperature is controlled by switching on or off one or more compressors (see **8.7.5 Compressor control**). Sequential changeover ensures that all compressors are loaded uniformly.

## 2.2. Evaporator

The evaporator is a plate heat exchanger which transfers heat from the cold water to the refrigerant. In order for the heat transfer to take place, the refrigerant in the evaporator has a lower temperature than the cold water and when it absorbs heat it changes its physical state from liquid to gaseous.

If the cold water is contaminated, deposits can form on the transfer surfaces of the evaporator. These impair the heat transfer to the refrigerant and reduce the refrigerating capacity of the machine. For this reason, always ensure the specified water quality and do not use any other additives than those specified.

## 2.3. Condenser

The condenser is a microchannel heat exchanger which transfers heat from the refrigerant to the ambient air. In order for the heat transfer to take place, the refrigerant in the condenser has a higher temperature than the ambient air drawn in and when it gives off heat its physical state changes from gaseous to liquid.

Contaminated cooling air can cause deposits to form on the surface of the condenser over time. This impairs heat transfer to the refrigerant which restricts the operating limit of the machine and reduces the machine's refrigerating capacity. Please refer to **Chapter 9: Cleaning** for a description of how to clean the condenser. If you operate your chiller in an environment containing dust or oil vapour, use the optionally available air filter mat (see **3.20 Air filter mat**).

In case that there already is an existing house water system and the warm condensing air has to be avoided, the chiller can also be specified with a water cooled condenser (see **3.3 Version with water cooled condenser**)

## 2.4. Expansion valve

The expansion valve controls the admission of liquid refrigerant to the evaporator and at the same time restricts the pressure of the refrigerant before it enters the evaporator. With this restriction the refrigerant cools to the evaporation temperature.

The expansion valve used in your machine is controlled electronically. The electronic control ensures that the evaporator is always optimally supplied with refrigerant. This improves the COP (Coefficient of Performance) and reduces pressure fluctuations in the refrigeration circuit.

## 2.5. Refrigerant

The refrigerant R410A circulates in the refrigeration circuit. It conveys heat from the evaporator to the condenser and at the same time continuously changes its physical state.

R410A is a fluorinated greenhouse gas consisting of the zeotropic mixture of 50% R32 and 50% R125 with virtually negligible temperature glide. R410A has a very high volumetric refrigerating capacity and has no ozone depletion potential (ODP=0). A corresponding safety data sheet can be obtained from our KKT chillers Service Team (see **Table 1: Contact details**).

## 2.6. Oil

The components of the compressor subject to friction are lubricated by oil, which is added to the refrigerant in the factory. The polyolester-160SZ is used for this. The oil is soluble in the refrigerant and is distributed with it throughout the refrigeration circuit. The total oil quantity of the respective unit is given in the technical data. A corresponding safety data sheet can be obtained from our KKT chillers Service Team (*see Table 1: Contact details*).

## 2.7. Filter dryer

The task of the filter dryer is to absorb any contamination or moisture from the refrigerant circuit. Both refrigerant and oil are hygroscopic. When the refrigeration circuit is installed the oil can absorb moisture. This moisture can cause corrosion and has a negative effect on the cooling process. The filter dryer bonds this moisture and also has a mechanical filter effect. If work is carried out on the refrigeration circuit requiring it to be opened, the filter dryer (cBoxX 30 – cBoxX100) respectively the filter cartridge (cBoxX 120 – cBoxX 200) must be replaced.

## 2.8. Pressure sensors

The pressure sensors used are compact pressure transmitters with piezoresistive measuring cell. The sensors register the system pressure continuously in different places within the refrigerant and cold water circuit. The values are used to control the system and for visualisation at the controller display.

## 2.9. Temperature sensors

The temperature sensors used are equipped with a platinum measuring cell. The sensors register the temperature continuously in different places within the refrigerant and cold water circuit. The values are used to control the system.

## 2.10. Control unit/ main circuit board

The control unit is programmed in the factory. All system readings and information come together on it. In addition, the electrical components are controlled via algorithms.

## 2.11. Display

The display is used to visualise the information required by the operator and the system processes. It is also possible to make entries at it. The display communicates with the control unit. Further information on operation is given in Chapter **8.5 Control panel**).

## 2.12. Control cabinet

The control cabinet conforms to the requirements of EN 60204 and contains the electrical and electronic components for controlling the chiller. After removing the operator control panel the control cabinet is accessible and can be opened using a standard two-way key. In order to avoid a damage of the main switch while demounting the side panel, the side panel has to be tipped 10cm on the bottom side. A circuit diagram is supplied with the unit.



Figure 2: Demounting the side panel of the switch cabinet

### 2.13. Pump

The chiller's pump ensures the necessary circulation of the cold water. The water is drawn out of the chiller's internal tank and is pumped through the process circuit. Optionally, the units can also be designed as a continuous flow cooler without tank, with pump or without tank, without pump (see Chapter **3.1 Version without tank, with pump**, and Chapter **3.2 Version without tank, without pump**).

### 2.14. Fan

The fan draws the cooling air from the surroundings through the condenser and blows out the heated air upwards out of the chiller. To prevent injuries, the fan is protected against accidental contact by protective grilles. The fan's speed is variable and is controlled by the main printed board. The speed of the fan is essentially controlled by the condensing pressure. The fan is protected against thermal overload. In units with two fans the speed of fan 1 is always the same as the speed of fan 2.

### 2.15. Cold water cycle

The cold water is drawn out of the chiller's internal tank by the internal pump and is pumped through the process circuit. Optionally, the units can also be designed as a continuous flow cooler without tank, with pump or without tank, without pump (see Chapter **3.1 Version without tank, with pump**, and Chapter **3.2 Version without tank, without pump**). In the process circuit the cold water absorbs heat. The circuit closes when the cold water is pumped back into the chiller. It flows through the evaporator, in which it gives off heat. The cold water then passes back into the tank. The cycle begins again.



## 2.16. Materials used in the water circuit

The material composition of the standard equipment is shown in **Table 5**:

**Table 5: Materials used - standard version**

Component	Material (cBoxX 30 – cBoxX100)
Unit connections	V2A 1.4305
Hose	Synthetic rubber band
Evaporator	V2A 1.4301 and copper (99.9%)
Tank	V2A 1.4301
Tank nozzle	V4A 1.4571
Pump	Grey cast iron and V2A 1.4301
Mechanical seal	EPDM
Sealing plugs yellow	Polyamide PA 6
Sealing plugs black	Polyoxymethylene (POM)
Filling and drain valve	Brass, nickel-plated
Bends, tees, couplings, fittings	Gunmetal CC499K , V4A 1.4408
Hose nozzle	Brass, nickel-plated
Angle swivel fitting (level indicator)	PVC and nickel-plated brass
Temperature sensor PT1000	V2A 1.4301
Pressure sensor XSK AC10I-U188	V2A 1.4301
Overflow valve (optional)	Gunmetal
Tank heating (optional)	Nickel-chromium-iron alloy Alloy 825

Component	Material (cBoxX 120 – cBoxX 200)
Unit connections	ABS, stainless steel 1.4307
Pipe and bends, T-pieces, reducers	Gunmetal CC499K , V4A 1.4408
Hose:	SBR black (styrene-butadiene rubber)
Hose nozzles:	Brass, nickel-plated
Threaded fitting:	Stainless steel V4A
Screw joint seals:	PTFE, Aramid (fibres) with NBR
Evaporator	V2A 1.4301 and copper (99.9%)
Tank	V2A 1.4301
Tank nozzle	V4A 1.4571
Pump	Grey cast iron and V2A 1.4301
Mechanical seal	EPDM
Sealing plugs yellow	Polyamide PA 6
Sealing plugs black	Polyoxymethylene (POM)
Filling and drain valve	Brass, nickel-plated
Angle swivel fitting (level indicator)	PVC and nickel-plated brass

If equipped with the optional **Water circuit in non-ferrous metal-free version** the material composition is as shown in **Table 6**:

**Table 6: Materials used for the non-ferrous metal-free version**

<b>Component</b>	<b>Material (cBoxX 30 – cBoxX100)</b>
Device connections (turned parts)	V2A 1.4305
Hose	Synthetic rubber band
Evaporator	V2A 1.4401
Tank	V2A 1.4301
Tank nozzle	V4A 1.4571
Pump	V2A 1.4301
Mechanical seal	EPDM
Sealing plugs yellow	Polyamide PA 6
Sealing plugs black	Polyoxymethylene (POM)
Filling and drain valve	V4A 1.4401
Fittings	V4A 1.4408
Hose nozzle	V4A 1.4408
Elbow screw connection (level indicator)	PVC and polyoxymethylene (POM)
Hose (fill level indicator)	PE natural
Temperature sensor PT1000	V2A 1.4301
Pressure sensor XSK AC10I-U188	V2A 1.4301
Overflow valve (optional)	V2A 1.4301
Tank heating (optional)	Nickel-chromium-iron alloy Alloy 825

<b>Component</b>	<b>Material (cBoxX 120 – cBoxX 200)</b>
Unit connections	ABS
Pipe and bends	ABS
Evaporator	V2A 1.4301
Tank	V2A 1.4301
Tank nozzle	V4A 1.4571
Pump	V2A 1.4301
Mechanical seal	EPDM
Sealing plugs yellow	Polyamide PA 6
Sealing plugs black	Polyoxymethylene (POM)
Filling and drain valve	V4A 1.4401
Elbow screw connection (level indicator)	PVC and polyoxymethylene (POM)
Hose (fill level indicator)	PE natural
Temperature sensor PT1000	V2A 1.4301

## 2.17. Water quality

The following limits must be maintained for safe operation of the equipment:

**Table 7: Water quality**

Property / components	Unit	Value range Standard version	Value range Non-ferrous metal-free version
pH value (20 °C)	-	7-9	6-9
Saturation index	-	-0.2 < 0 < +0.2	-0.2 < 0 < +0.2
Conductivity	µS/cm	80-500	5-500
Water hardness	°dH	<5.6	<5.6
Carbonate hardness	mol/m <sup>3</sup>	<0.5	<0.5
Total plate count	K/ml	<10,000	<10,000
Grain size	µm	< 250	< 250
Glycol fraction (AFN)	% by vol	20-40	20-40
Oil fraction	% by vol	0	0
Chloride (Cl <sup>-</sup> )	mg/l	<50	<50
Sulphate	mg/l	<50	<50
Nitrate	mg/l	<100	<100
Copper	mg/l	<0.1	<0.1
Iron	mg/l	<0.2	<0.2
Free carbonic acid	mg/l	<20	<20
Manganese	mg/l	<0.1	<0.1
Ammonia	mg/l	<2	<2
Free chloride	mg/l	<0.5	<0.5
Sulphide	mg/l	<0.03	<0.03

In order to avoid a restriction of the plate heat exchanger the above listed limit values have to be guaranteed imperatively.

Furthermore mucilage bacteria are not allowed in the cooling water. If that is not possible, KKT chillers can recommend an accordant inhibitor based on a biologic water analysis.

## 2.18. Permitted cooling media

Water and mixtures of water / Antifrogen N (AFN) or water / Antifrogen L (AFL) according to the details given in **Chapter 2.17 Water quality**. The following table shows the requirements for the mix ratio of water with the antifreezes AFN or AFL. To maintain the performance of your machine and prevent damage to components, these values must be maintained as precisely as possible.

	<p><b>ATTENTION! Do not mix different antifreezes. This can cause unwanted chemical reactions and silting up.</b></p>
---	---

**Table 8: AFN and AFL mix ratios (or equivalent)**

Setting	Frost-free at t-environment to	AFN mix ratio	AFL mix ratio
Glycol 20 - 25 %	-10 °C	20-25 %	25-30 %
Glycol 30 - 35 %	-15 °C	30-35 %	32-37 %
Glycol 40 %	-25 °C	40 %	42 %

### 3. Options and accessories

The chiller can be equipped in the factory with the options described in the following.

The items marked "accessories" are enclosed with the unit, unattached, and can be reordered at any time using the appropriate product number. The installer of the machine is responsible for installing the accessories. You can also ask our KKT chillers Service Team to arrange for this installation (see **Table 1 Contact details**).

Details of your machine's equipment are given in the separate summary documentation.

#### 3.1. Version without tank, with pump

The Compact-Line units are also optionally available as continuous flow chillers. In this case the units are delivered without an internal tank. The temperature sensor is then located in the chiller's return line. If a tank open to the atmosphere is integrated on site, it is necessary to ensure that the tank is not installed at a lower level than the chiller. Additional pressure losses between the tank on site and integrated pump must be avoided ( $dp_{max}=0.3bar$ )

#### 3.2. Version without tank, without pump

The Compact-Line units are also optionally available as continuous flow chillers. In this case the units are delivered without an internal tank and without pump. The temperature sensor is then located in the chiller's return line. The cold water is then circulated via the evaporator by a pump to be installed on site. This must at least be designed to the pressure loss of the overall system.

#### 3.3. Version with water cooled condenser

Whereas the basic versions of the Compact-Line is specified with an air cooled condenser, the units are also available with an water cooled condenser.

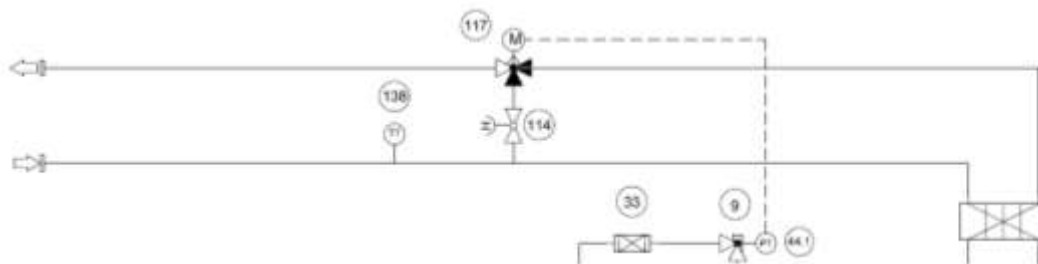

Thereby the condenser is a plate heat exchanger with copper brazed stainless steel plates. The 3way valve is mounted in the cooling water outlet and is adjusted by an actuator depending on the condensing pressure. The operation mode can be switched from the 3way operation to a 2way operation by closing the pre mounted bypass valve. The cooling water temperature is measured by an additional temperature sensor in the cooling water inlet and is shown at the controller display.

	<p><b>The water quality shown in Table 7: Water quality has to be guaranteed imperatively – the manufacturer does not assume liability for damages caused by other water qualities.</b></p>
---	---

The project specific data as well as the adapted hydraulic scheme and the dimension sketch can be found in the additional short documentation.

#### **3.4. Heater for compressor and control cabinet**

The oil sump heater prevents refrigerant from becoming deposited in the oil of the compressor at low ambient temperatures. When the compressor is started up this refrigerant would be liberated from the oil as gas and make the oil foam up. Under these basic conditions the lubrication of components in the compressor subject to friction would be poor and the compressor could be damaged.

The control cabinet heating is controlled thermostatically and, at low ambient temperatures, it prevents moisture from the ambient air drawn in condensing on the electrical and electronic components of the cabinet thereby damaging them.

For both heaters to be active, the chiller must not be disconnected from the power supply (**8.2 Selecting the operating mode**).

#### **3.5. Insulation of the cold pipes and the pump(s)**

To prevent condensation on cold chiller pipes, where high temperature differences exist between the surroundings and cold water flow and taking into account the relative humidity the option of insulation of the cold pipes must be specified.

#### **3.6. Tank heater with thermostatic pump start**

The tank heater in conjunction with the thermostatic pump start serves to maintain a minimum temperature in the tank. The pump circulates the cold water while the tank heater regulates the temperature in the system. A hydraulic installation as shown in **Fehler! Verweisquelle konnte nicht gefunden werden.** is recommended. Thus, any bypass valves must always be installed frost-free. The fact that the tank heater and the thermostatic pump start can be active, the chiller must not be disconnected from the power supply (main switch ON!!!!). The thermostatic pump start is effective in standby and auto modes without external approval. The tank heater works in all operating modes while the pump is running.

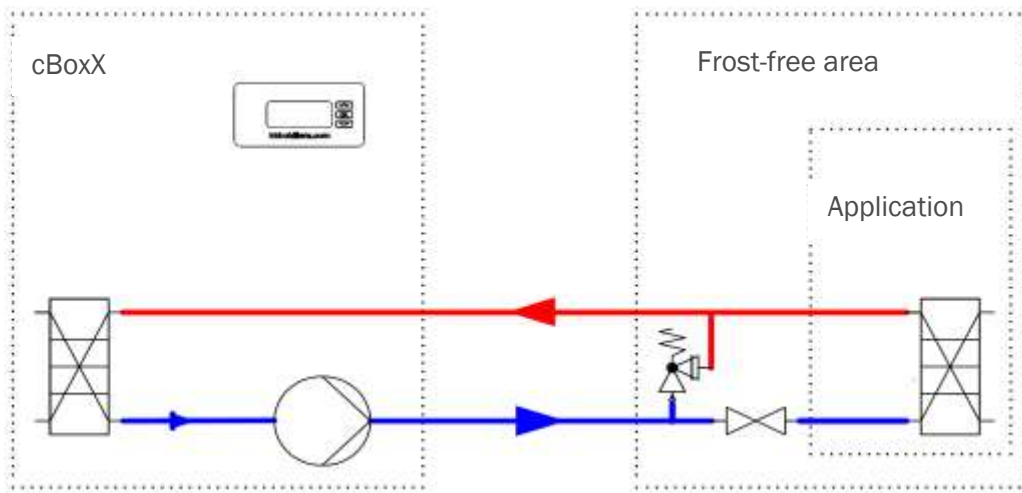

Figure 3: C6856 thermostatic pump start with overflow valve (recommended installation)

### 3.7. Overflow valve for standby mode

The optional overflow valve should be installed if it is possible for the flow of the cold water to reduce sharply or be completely prevented while the unit is running. The internal overflow valve ensures the minimum volumetric flow through the chiller and therefore prevents the pump from switching off. **Figure 4** shows the position of the internal overflow valve.

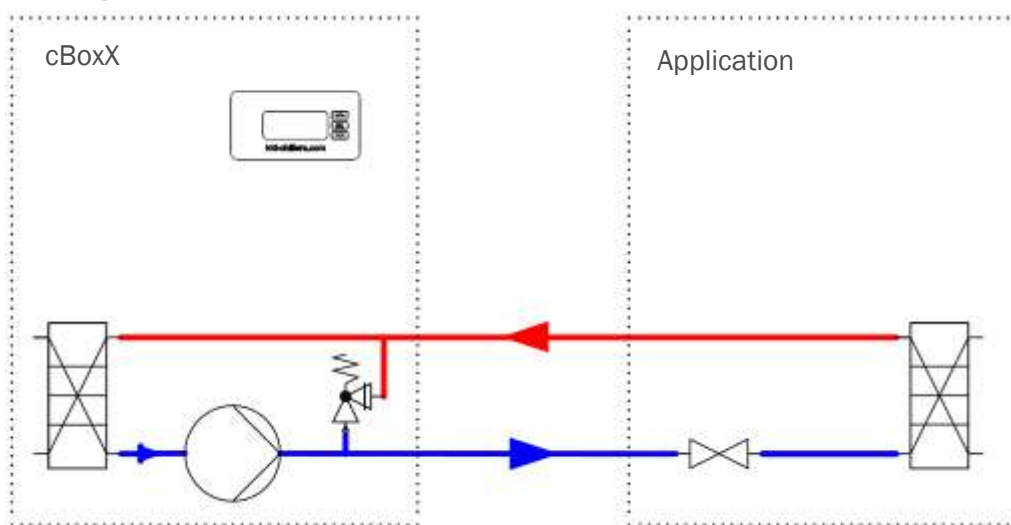

Figure 4: C6863 overflow valve for standby mode

### 3.8. Higher pressure pump

The standard Compact-Line units have a 3 bar pump, which is designed for the nominal volumetric flow of the respective unit. Optionally the units can also be built with higher pressure pumps, within the limits of the minimum or maximum volumetric flow (**1.2 Technical data**). The pump characteristic curve of the pump(s) used in your unit is enclosed with the unit.

### 3.9. Second consumer circuit

The standard Compact-Line units have a 3 bar pump, which is designed for the nominal volumetric flow of the respective unit. If several consumers with different water specifications are to be cooled with one unit, the unit can also be supplied with an optional second cold water circuit. Ask your KKT chillers contact.

### 3.10. Additional evaporator pump

The evaporator is optimised for the nominal volumetric flow rate of cold water. The nominal volumetric flow rate is given in **Table 3 Technical data**.

If the operating volumetric flow rate of the cold water is more than 50 % smaller, an evaporation pump must be installed. The evaporator pump circulates the cold water internally and keeps the storage water at feed temperature. A second pump supplies the process circuit with cold water.

### 3.11. Frequency controlled pump

The standard Compact-Line units have a 3 bar pump, which is designed for the nominal volumetric flow of the respective unit. If the consumer is to be cooled with changing water specifications, the unit can optionally be equipped with a frequency-controlled pump. By changing the speed, the pressure and the volume flow are adapted to the current situation either manually or automatically. In the controller display you can choose between the settings Auto / Manuel / 0% / 100%.

- Auto: Control takes place to the pressure set in the controller.
- Manual: The speed entered in the controller is controlled in 0-100% = 0-10V.
- 0%: The pump is controlled with 0% (0V). It runs at minimum speed.
- 100%: The pump is controlled with 100% (10V). It runs at maximum speed

Please note that this option is only available in conjunction with an evaporator pump to ensure a constant volume flow through the evaporator.

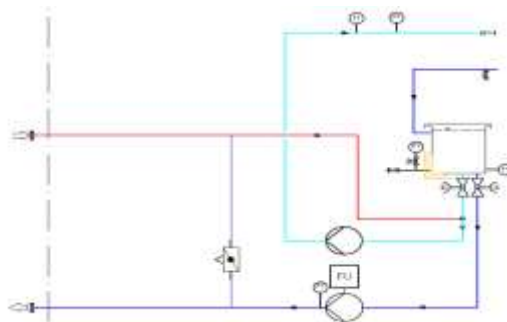

### 3.12. Automatic water feed

Any leaks and evaporation can cause the quantity of cold water available for the chiller function to reduce during the course of operation of the chiller. The **Automatic water feed** option provides the possibility of topping up the cold water circuit automatically. The tank contents are monitored continuously and if necessary topped up until it has again reached the optimum level. In this case the operator only has to connect the chiller to the building's water system via the feed connection (see **Figure 5**). The inlet pressure must lie between 1 bar and 10 bar.



Figure 5: Top-up connection

If you operate your chiller with a mixture of water / glycol and top up only with pure water, you must check the glycol content of the circuit water at regular intervals and if necessary adjust it.

### **3.13. Water circuit in non-ferrous metal-free version**

If your machine is a non-ferrous metal-free version, all parts of the chiller's cold water circuit in contact with the media are free from non-ferrous metals. Certain components such as the evaporator and pump are suitably modified. The materials used in the water circuit are listed in **Table 6**.

### **3.14. DI package**

The DI package contains the non-ferrous metal-free option for the water circuit (see **chapter, 3.12**) and a replaceable DI cartridge with conductivity monitoring and control.

### **3.15. Special voltage**

The special voltage option describes the use of the aggregate outside the voltage supply of 400V ( $\pm 10\%$ )/3phases/50Hz. Here alternative components (e.g. compressors, pumps or fans) as well as an autotransformer (integrated or unattached) can be used.

For chillers with an integrated autotransformer sizes cBoxX 30 to cBoxX100, the transformer is located in an additional flanged-mounted housing; for sizes cBoxX 120 to cBoxX 200 it is located in the existing housing. For exact specifications, please refer to the circuit diagram. Please get in touch with your KKT chillers contact person for further information on implementing this option.

### **3.16. Phase monitoring**

The Compact-Line units can be equipped with optional phase monitoring. This monitors the phase sequence, phase failure, undervoltage and asymmetry and covers a voltage range of 200-690V. If the respective predefined limits are exceeded the system switches off and protects the electrical components installed in the unit.

### **3.17. Hot gas bypass for output control <1K**

If a more precise target constant than  $\pm 1$  Kelvin is required, the chiller can be equipped with an output control. In this case the output of the refrigeration circuit is adjusted to the cooling demand by an electronically controlled valve. Unlike the standard control by switching compressors on or off, a higher target constant is achieved by the continuous regulation of the valve.

### **3.18. High-temperature package**

In principle, the units must be operated within the given ambient temperature range (see **Table 3**). If the high-temperature package is selected, the unit can be operated at an ambient temperature of up to 50 °C without high-pressure faults.

### **3.19. Special paint finish**

While the condenser's protective grille is always painted in RAL 7015 anthracite black, the cladding panels (**1.2 Elements**) can also be optionally finished in special colours.



### 3.20. Air filter mat (accessories)

If the chiller is operated in surroundings with dust or oil vapour the condenser should be protected with the air filter mat. The filter is fixed using the Velcro tapes attached in the condenser protective grille. The filter is cleaned by removing it and washing it with water or a slightly alkaline solution. Heavily-contaminated filters must be replaced by new ones. Please contact the KKT chillers Service Team (see *Table 1 Contact details*).

### 3.21. Levelling feet (accessories)

The levelling feet are used for vibration isolation and for height adjustment. They consist of a threaded rod and a grey cast iron shell with an elastic element attached. The threaded rod enables the height to be adjusted and compensates for floors sloping by up to 5°. The elastic element has a slip-resistant covering. *Figure 6* and *Figure 7* show the installed machine foot – the technical drawing is given in the appendix.



Figure 6: Machine base (foot) – outside view



Figure 7: Machine base (foot) - mounting on the baseplate

### 3.22. Level package (accessories)

The level package is used if the application is to be installed more than 500 mm above or below the chiller (see also *Chapter 6.2.6 Process level*). This option is delivered uninstalled and consists of an electronically controlled valve and a non-return valve. The electronically controlled valve must be installed at the unit inlet, the non-return valve at the unit outlet. The electronically controlled valve is installed electrically in the control cabinet as shown in the circuit diagram.

### 3.23. Filter assembly group coolant circuit (accessories)

The water filter protects the coolant circuit against dirt. The set, consisting of a filter, fitting and two shut off valves, is enclosed with the chiller in a separate pack and must be fitted onto the cold water inlet of the chiller from the outside when the chiller is installed.

### 3.24. Filter assembly group cooling water circuit (accessories)

The water filter protects the cooling water circuit against dirt. The set, consisting of a filter, fitting, two shut off valves and two pressure gauges for displaying the cooling water inlet- and outlet pressure is enclosed with the chiller in a separate pack. The installation can be either mounted for shutting of the filter group or for shutting of the complete cooling water circuit.

### 3.25. MultiplexX connection group (accessories)

If the refrigerating capacity of a chiller is not sufficient, several units of the same type can be combined in the version with tank and pump. A MultiplexX connection group can be ordered for this purpose and consists of the level package (**3.22 Level package**) and a corresponding connection kit for the flow balance between the tanks. The refrigerating capacity of the individual units can then be added together. Please contact your KKT chillers contact to arrange the appropriate project planning for this option.

### 3.26. Refill cartridge R410A (accessories)

Chillers with refrigerant capacity >12kg must be declared as dangerous goods in accordance with UN2857 (**5.1 Dangerous goods**). The optional R410A refill cartridge is available for units with refrigerant capacities >12kg (cBoxX 120- CBoxX 200) so that you do not incur any additional logistics costs. Following the performance check in the factory, a quantity of refrigerant is filled in a certified refrigerant cylinder so that the 12kg limit is kept to in the unit. The refill cartridge is then delivered together with the unit. The refrigerant quantity drained for transport can be returned to the system as part of the commissioning using the summary description provided with the refill cartridge.

### 3.27. Anybus-Gateway (accessories)

The Anybus-Gateway is ready mounted in the switch cabinet and can be used as an interface for processing all chiller signals. Therefore the following processing protocols are available depending on the customer specification:

available	upon request
<ul style="list-style-type: none"><li>▪ Profinet</li><li>▪ Profibus</li><li>▪ BACnet</li></ul>	<ul style="list-style-type: none"><li>▪ CANopen</li><li>▪ Devicenet</li><li>▪ EtherNet</li><li>▪ EtherCAT</li><li>▪ ControlNet</li><li>▪ CC-Link</li><li>▪ Modbus</li></ul>

A Modbus TCP communication is already included on the display pcb as a standard feature. An Anybus gateway is not required.

### 3.28. Remote Control Panel (accessories)

For the case that the chiller shall be operated not from the machine itself but from a different operating place the chiller can be delivered with a remote control panel. Thereby the same display is mounted together with the operating voltage supply in one miniature housing. The remote control panel is connected to the chiller with clips and takes over the complete function of the controller in the main device. By switching the accordant bridge integrated in the control cabinet, the required operating place can be chosen.

(in = internally installed control / out = outward leading control)

### 3.29. Special languages (accessories)

These instruction manuals are provided in German, English, French and Spanish. Other languages are available on request.

### 3.30. Wooden Crate (accessories)

Whereas the chillers of the Compact-Line are delivered on a wooden palette with Styrofoam corners stretched in the foil as a standard, the chillers can be also ordered in a wooden crate. There the chillers are protected additionally by a wooden crate with IPPC-Label according ISPM 15.

### 3.31. Seaworthy crate packaging (accessories)

Seaworthy crates for the Compact-Line are produced according to International Standards for Phytosanitary Measures with packaging made of solid wood (ISPM 15). This means that the crates are made of heat-treated solid wood which has been stripped of its bark. Only wood-based materials, such as OSB boards, are used. In addition, all crates are marked with the IPPC logo and registration number. The units are fixed in the crate with the help of coach bolts, ring nuts and polyester straps and are packed in a sea air consistent foil with desiccant. The components used to pack the units can be dismantled using a cross-head screwdriver.

### 3.32. Water Pump Redundancy

Depending on the optional configuration, the cboxX (water chiller) can be equipped with a dual water pump for redundancy and increased life time of the pump itself. The operating hours of the pumps are programmable and can be shared by both pumps (f. e. 24h switch on/off between both pumps). If one pump fails, the second pump also switches on automatically, thus ensuring safe operation.

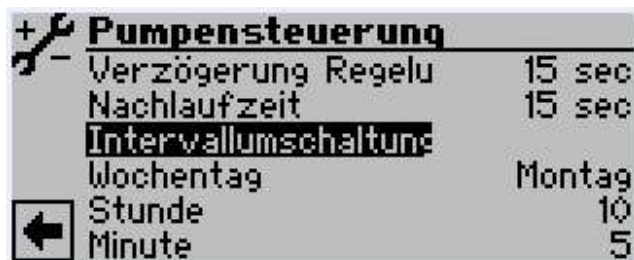

<b>+ 🔑</b>	<b>Pumpensteuerung</b>	
<b>⚙️ -</b>	Verzögerung Regelu	15 sec
	Nachlaufzeit	15 sec
	<b>Intervallumschaltung</b>	
	Wochentag	Montag
<b>⬅️</b>	Stunde	10
	Minute	5

### 3.33. Closed Water Loop

The water chiller is designed as a closed water loop system with an expansion tank. The expansion tank is pressurized in accordance with the volume of the entire system volume (including installation). The expansion tank balances temperature swings and related system pressure of the water loop. In case the coolant temperature rises the expansion tank takes in the expanded volume of the coolant and if the coolant temperature falls the stored volume will be released back into the loop again.

Advantages of a closed water loop system are:

- No top up or refill required, due to no evaporation of the coolant
- No dirt or algues in the coolant
- No cleaning required of the tank
- Reduces weight of the chiller

### 3.34. Energy meter

The energy meter of the compact-line shows the current electrical consumption values in the display and records them over the entire runtime.

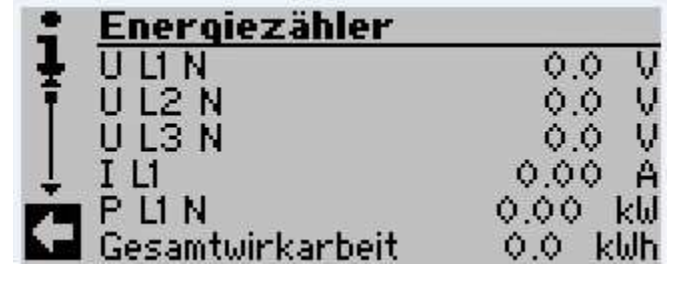
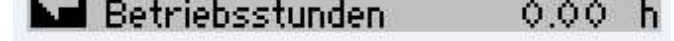
	<p>Outer conductor voltage L1 Voltage Voltage Outer conductor current L1 Electrical power between outer conductor L1 &amp; neutral conductor Total electrical output</p>
	<p>Operating hours begin to count after the system is switched on</p>

## 4. Safety

Provided it is used as intended, the chiller is designed to operate safely, provided also that the instructions concerning transport, installation, commissioning/startup and maintenance given in these operating instructions are complied with. The machine conforms to the safety standards in accordance with the EC Declaration of Conformity (see **Appendix VII**).

### 4.1. General information

- The chiller contains a high-pressure circuit. The maximum pressure that occurs is 45 bar. Even when inactive or disconnected from the power supply the circuit is still under pressure.
  
- Pressure surges in the system must be avoided. These can occur, for example, due to fast-closing valves or the closing of valves during pump operation. Such shocks can cause damage to the unit!

### 4.2. Hazard warnings









A number of warning labels are applied to the machine. Keep these warnings clean at all times. Damaged or missing warnings must be replaced.

Table 9: Definition of the safety symbols

	Note and follow the instructions for use!
	Before opening the machine it must be disconnected from the power supply! After disconnecting the machine from the power supply, always wait for at least 5 minutes before opening it.
	Danger! High voltage! If the machine is only switched off at its main switch, dangerous electrical voltage is still present at several terminals in the control cabinet.
	Wear foot protection!
	Wear hand protection!
	Wear eye protection!
	Wear protective clothing!
	Warning! Hot surface!
	Warning! Cold surface!
	ATTENTION!
	Contains pressurised gas!

In particular, the following hazard warnings apply to the machine:

Table 10: Hazard warnings

	<p><b>ATTENTION!</b> Work on the chiller must be carried out by properly qualified, competent personnel!</p>
	<p>The surfaces of pipes and components of the refrigerant and cold water circuit and electrical equipment can be very hot during operation and even for a while after.</p>
	<p>The surfaces of pipes and components of the refrigerant and cold water circuit and electrical equipment can be very cold during operation and even for a while after.</p>
	<p><b>ATTENTION!</b> Pipes and components of the refrigerant and cold water circuit are pressurised.</p>
	<p><b>ATTENTION!</b> Do not undo the system parts. Risk of injury on contact.</p>
	<p><b>ATTENTION!</b> Only use the specified liquids!</p>
	<p><b>WARNING!</b> The device frame as well as the housing have not been designed for additional loads, which is why it is not permitted to enter or place any additional loads on the components!</p> <div style="display: flex; justify-content: space-around; align-items: center; margin-top: 20px;"> <div style="text-align: center;">  <p>Do not enter</p> </div> <div style="text-align: center;">  <p>No additional loads</p> </div> </div>

### 4.3. Residual energy

Even if all the hazard warnings in the chapter above are taken into account, the following residual energy situations can result in a hazard:

- Rotational energy of the decelerating fan
  - Despite the installed protective grille, hair or pieces of clothing can still be drawn in and caught.
- Hot surfaces on machine parts
  - Especially the compressor head and the hot gas pipe and the condenser can still be very hot for some time after the machine has been switched off. Temperatures within the range from 60 °C to 90 °C are possible.
- Dangerous electrical voltage in the control cabinet despite the switched off main switch
  - If the machine is only switched off at its main switch, dangerous electrical voltage is nonetheless still present at several terminals in the control cabinet. In particular, these are the main supply terminal and the input terminals of the main switch.
- Refrigeration circuit is pressurised
  - Provided it is not damaged the refrigeration circuit is closed. Therefore, a hazard is not to be assumed.

#### Note:

After switching off the unit at the main switch, if you wait for 5 minutes before opening the unit risks due to rotational energy and electrical power can be reduced. In this case only the residual thermal energy must be considered.



#### 4.4. Safety devices, guards and safeguards

##### 4.4.1. High-pressure limiter

The high-pressure limiter (PZH) is a pressure switch with manual reset. The PZH limits the condensing pressure and switches off all compressors via their load contactors when the maximum permitted system operating pressure is reached. It is part of the safety chain. The PZH is installed on the refrigerant collector for the chiller types cBoxX 30 – cBoxX 200 and on the fluid pipe for the chiller types cBoxX 120 – cBoxX 200 (see *Figure 8: Position of the high-pressure limiter (PZH)*). If the PZH has triggered, a message appears at the operator control terminal. In this case, please follow the instructions in the *Troubleshooting chapter (see Appendix IV)*.



High pressure limiter (PZH)  
cBoxX 30 – cBoxX 100

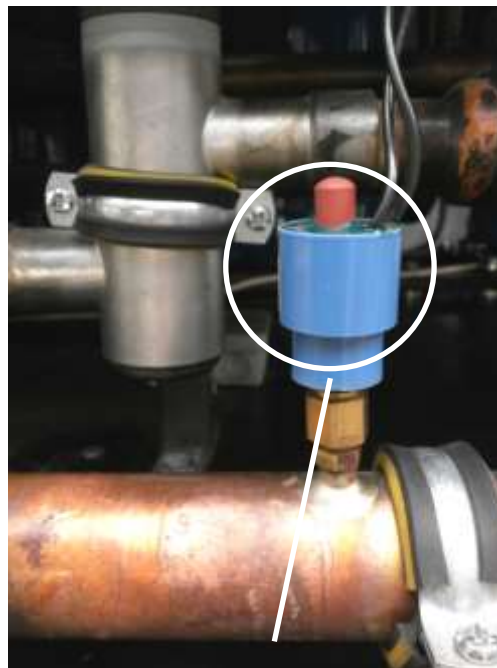

High pressure limiter (PZH)  
cBoxX 100 – cBoxX 200

**Figure 8: Position of the high-pressure limiter (PZH)**

#### 4.4.2. High-pressure monitoring

If the high pressure in the refrigeration circuit of your machine increases to a maximum value, the compressors are switched off via the **High-pressure limiter** (see **Chapter 4.4.1 High-pressure limiter**). A manual reset is required. The high-pressure monitoring on the other hand reduces the compressor output before the PZH's switch-off value is reached. This is done by successive switching off of one or more compressors. A message appears at the control panel. When the high pressure has reduced to a minimum value of 31.5 bar, the compressors are released once more. In most cases partial shutdown of the compressors enables operation of the chiller to be maintained with reduced output. If the high-pressure monitor has triggered, please follow the instructions in the **Troubleshooting chapter (see Appendix IV)**.

#### 4.4.3. Low-pressure monitoring

If the low-pressure in the refrigeration circuit of your system is too low for the specified cooling medium there is a risk of freezing. For this reason the low pressure is monitored continuously and if it falls below a minimum value, one or more compressors are switched off successively. A message appears at the control panel. If the low pressure has increased to a minimum value the compressors are released once more. In most cases partial shutdown of the compressors enables operation of the chiller to be maintained with reduced output.

If the low-pressure monitor has triggered, please follow the instructions in the **Troubleshooting chapter (see Appendix IV)**.

#### 4.4.4. Flow monitoring

If the volumetric flow of the cold water which is pumped through the evaporator is too low, there is a risk of freezing. For this reason the flow through the evaporator is monitored continuously. If the volumetric flow rate is only around 50 % of the nominal volumetric flow rate, the message "Flow warning" appears.

If the rate falls below the minimum value of 20 % the compressors are switched off and the message "Flow stop" appears. In this case, please follow the instructions in the **Troubleshooting chapter (see Appendix IV)**.

#### 4.4.5. Personal protective equipment when operating the machine



Operating the machine involves making settings at the control panel. During operation of the machine its cladding panels are installed, the machine is completely enclosed. No protective equipment is needed.

We recommend ear protectors be worn by persons with jobs that require them to be continuously in the immediate vicinity of the chiller. Please refer to the sound emission information included in the technical data.

#### 4.5. Personal protective equipment for servicing work

Servicing work on the machine includes all work for which the machine is opened and one or more cladding panels are dismantled. In particular, this includes cleaning work in accordance with **Chapter 9 Cleaning** and maintenance work in accordance with **Chapter 10 Service**. Before work is carried out on the chiller the protective equipment described in **Table 9: Definition of the safety symbols** must be used.

Table 11: Personal protective equipment for servicing work

	<b>Wear foot protection!</b>
	<b>Wear hand protection!</b>
	<b>Wear eye protection!</b>
	<b>Wear protective clothing!</b>

#### 4.6. Airborne sound emissions

The airborne sound emissions data is given as the sound pressure level, measured at a distance of five metres without reflection. Its maximum value is shown in the technical data. This only occurs at the highest fan speed at the air intake side of the chiller (**Figure 9**, measuring point [1]). The emissions in [2] to [4] are generally around 10 % lower than [1].

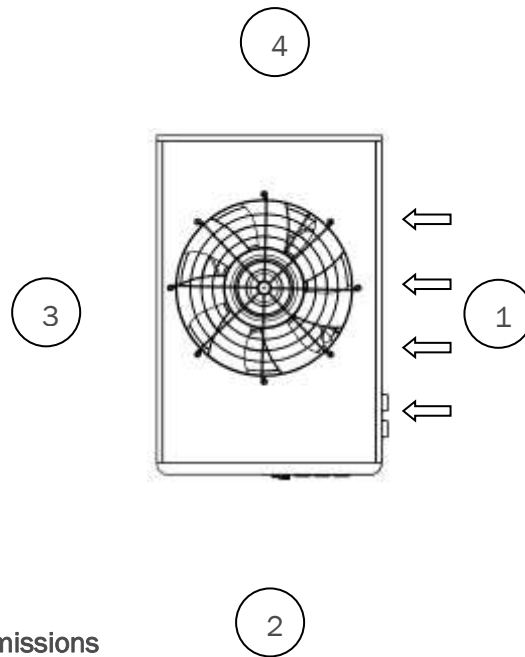

Figure 9: Airborne sound emissions

In partial load mode or under favourable ambient conditions (see **Chapter 4.7.1 Noise**) the fan speed and therefore the sound emissions reduce automatically.

#### 4.7. Notes on reducing noise and vibration

##### 4.7.1. Noise

Details of your chiller's airborne sound emissions are given in **Chapter 4.6**.

To reduce noise pollution caused by airborne sound emissions it is advisable to install the chiller out of doors and out of the range of workplaces.

If this is not possible we recommend that when the unit is installed attention is paid to ensuring that the air intake side is not pointed directly at a workplace/workstation.

High ambient temperatures mean high fan speeds and this increases the noise levels produced. It is advisable not to expose the chiller to direct sunlight or to install it in rooms with high air temperature. Further information is given in **Chapter 6.2 Installation site**.

##### 4.7.2. Vibration

The chiller is designed so that the vibrations caused by the compressor are largely isolated by the chiller's frame.

To minimise the effect of vibration still further it is possible to install the chiller with optionally available levelling feet (**3.21 Levelling feet**). These are fitted with damping elastomers.

## 4.8. Residual risks

### 4.8.1. Electrical

	<p><b>ATTENTION!</b> The mains voltage must comply with the quality features of EN 50160 and the defined standard voltages of IEC 60038.</p> <p>The electrical connection on the building side is the responsibility of the operator. The operator must ensure that the permissible limit values in DIN EN 60204-1 (occurrence of a leakage current to earth at any mains connection of more than 10 mA AC or DC) are complied with, and that measures are taken to reduce them to non-critical values if they are exceeded.</p>
---	--

If all safety provisions are complied with there is no risk.



The operator of the installation must initiate appropriate measures to reduce the leakage currents in his system to a minimum.

### 4.8.2. Mechanical



If all safety provisions are complied with there is no risk.

Mechanical damage to components or pipes of the refrigerant circuit can cause refrigerant to leak. Leaking refrigerant can cause cold burns.

### 4.8.3. Chemical

	<p><b>ATTENTION!</b> Toxic and caustic products are produced by the thermal decomposition of the R410A refrigerant.</p>
	<p><b>ATTENTION!</b> Do not install in rooms with naked flames or smoke.</p>

### 4.8.4. Other

	<p><b>ATTENTION!</b> Risk of suffocation if the chiller is installed in a room that is too small. Please note and follow <i>Chapter 6.2.2</i>.</p>
	<p><b>ATTENTION!</b> In the EU you must follow the provisions of EN378-3. Please also note and follow the local installation regulations and provisions, especially the Ordinance on handling water pollutant substances and BGR500 Chapter 2.35.</p>

## 4.9. Dangerous substances

### 4.9.1. Refrigerant R410A

First aid measures:

- After inhaling: remove victim to fresh air, ensuring your own safety, and keep the person at rest in a comfortable position. Get medical attention. If the person stops breathing, give artificial respiration.
- Following skin contact: leave clothing that has fused with the skin. Rinse areas damaged by cold with lukewarm water (never use hot water). Do not rub! Cover with sterile dressing. Ensure medical treatment is provided.
- Following eye contact: rinse the eyes with clean water or eyewash solution for at least 15 minutes with the eyelids open. Consult an eye specialist.
- After swallowing: swallowing is not considered to be a likely risk as the refrigerant in the surroundings is gaseous.

Notes for the doctor: do not give the patient catacholamine or adrenalin ephedrine preparations.

Fire-fighting measures:

- Suitable extinguishing agents: The product itself does not burn. Match the extinguishing measures to the surrounding fire. Cool containers with sprayed water.
- Particular hazards due to the substance, its combustion products or gases formed: forms toxic and caustic gases and fumes on decomposition.
- Special protective equipment for fire-fighting: self-contained or air-line breathing apparatus and acid-resistant protective suit for deployment in immediate vicinity.
- Further information: The effect of fire can cause bursting or explosion of the container. Ignitable gas-air mixtures possible under certain conditions.

Measures in case of accidental release:

- Environmental protection measures: where possible do not allow the product to get into the environment.
- Cleaning procedure: leave the product to evaporate.

Handling and storage:

- Handling: fire and explosion protection: heating results in increased pressure and a risk of bursting. Cool containers at risk with water. Open the containers slowly and carefully.

Personal protective equipment:

- Respiratory protection: not necessary if adequate ventilation available. Self-contained or air-line breathing apparatus within enclosed rooms, if insufficient oxygen supply available, in case of substantial or uncontrollable release. Only use breathing apparatus in accordance with the international / national standards. Only use breathing apparatus, no filtering devices.
- Hand protection: chemical-resistant protective gloves. Recommended material: Polyvinyl alcohol.
- Eye protection: close-fitting safety glasses/goggles.

General protection and hygiene measures:

- Do not inhale fumes / aerosols.
- Do not eat/drink or smoke during work.

#### 4.9.2. Oil POE 160SZ

First aid measures:

- After inhaling: remove victim to fresh air, ensuring your own safety, and keep the person at rest in a comfortable position. Get medical attention.
- Following skin contact: remove soiled, soaked clothing. Wash skin with water. If symptoms develop, get medical advice.
- Following eye contact: rinse the eyes with clean water or eyewash solution for at least 10 minutes with the eyelids open. Consult an eye specialist.
- After swallowing: can cause vomiting. Have the mouth rinsed out with water and give the patient two glasses of water to drink. Get medical advice.
- Notes for the doctor: symptomatic treatment and assistive therapy as indicated.

Fire-fighting measures:

Low fire risk. Product only ignites in case of very large heat supply.

- Suitable extinguishing agents: match to the surroundings. Carbon dioxide, powder and foam extinguishing agents. Use water with caution to avoid possibly considerable steam generation.
- Particular hazards due to the substance, its combustion products or gases formed: irritant fumes are released during thermal decomposition.
- Special protective equipment for fire-fighting: self-contained or air-line breathing apparatus and acid-resistant protective suit for deployment in immediate vicinity.
- Further information: The effect of fire can cause bursting or explosion of the container. Ignitable gas-air mixtures possible under certain conditions.

Measures in case of accidental release:

- Environmental protection measures: do not allow the product to get into the sewers or bodies of water. Absorb with sand, soil or a similar absorbent material. Ensure proper disposal in containers.
- Cleaning procedure: Clean the contaminated area with water. Caution! Slipping hazard!
- Further information: Inform the police or competent authorities in case of penetration in the sewers or bodies of water.

Personal protective equipment:

- Respiratory protection: Not necessary if adequate ventilation available. Self-contained or air-line breathing apparatus within enclosed rooms, if insufficient oxygen supply available, or in case of substantial or uncontrollable release. Only use breathing apparatus in accordance with the international / national standards. Only use breathing apparatus, no filtering devices.
- Hand protection: protective gloves. Recommended material: nitrile rubber.
- Eye protection: close-fitting safety glasses/goggles.

Handling and storage:

- Handling: avoid lengthy skin contact. Avoid inhaling high concentrations of vapour or fumes.
- Storage: suitable material for containers: mild steel. Tightly close unused containers to prevent the penetration of moisture. Store away from strong oxidants.

#### **4.10. Reasonably foreseeable misuse**

Reasonably foreseeable misuse, for the users of the chiller, means foreseeable use in a way not intended according to the operating instructions. It is due to foreseeable human behaviour.

The following Dangerous situations can arise due to misuse which could reasonably be expected:

- dangerous voltage of electrical components, if the machine is not disconnected from the power supply before it is opened.
- the fan and compressor can start up suddenly, without any visible change to the machine's state.
- even if the machine has been disconnected from the power supply, the surfaces of components in the unit can still be very hot or cold.
- risk of damage to external hydraulic components if the cold water feed is confused with the cold water return.
- danger caused by using media in the unit that have not been approved.
- danger caused by connecting an incorrect source of power.



#### 4.11. Information for emergencies

If an emergency occurs during operation of the chiller the machine must be disconnected from the mains at once using the master switch. Remove people from the danger zone immediately. An emergency situation can among other things be:

- a leak and escape of refrigerant and/ or oil.
- a part of the machine becoming mechanically detached from it.
- the machine making unusual noises.
- the machine vibrating severely.

Then contact the KKT chillers Service Team. If you detect a refrigerant or oil leak, proceed as described in **Chapter 4.9 Dangerous substances**.

### 5. Handling and storage

The chiller is fixed on a wooden pallet in the factory for delivery. The machine is additionally protected against damage by polystyrene corner protectors and stretch film. Therefore you should remove the packaging as late as possible.

#### 5.1. Dangerous goods

Chillers with refrigerant capacity >12 kg must be declared as dangerous goods in accordance with UN2857. The cBoxX 30 – cBoxX 100 chillers have been specified so that they contain <12 kg refrigerant. The cBoxX 120 – cBoxX 200 chillers basically have a refrigerant filling >12kg. In order to avoid the declaration as dangerous goods also for these types, the option **Refill cartridge R410A (accessories)** (see chapter 3.26) can be ordered. Following the performance check in the factory, a quantity of refrigerant is filled in a certified refrigerant cylinder so that the 12kg limit is kept to in the unit. The refill cartridge is then delivered together with the unit. The refrigerant quantity drained for transport can be returned to the system as part of the commissioning using the summary description provided with the refill cartridge.

#### 5.2. Transport

The chiller may only be transported using a fork lift truck or crane with sufficient rated capacity. The net weight of your machine is given in the technical data. Please note that if a machine has already been in operation, it can contain residual fluids, which increase the transport weight.



**ATTENTION! The chiller must not be tilted by more than 10° from the perpendicular position.**

### 5.2.1. Forklift truck

It is possible to transport the machine both in a packed and an unpacked condition by means of forklift truck. In this case, please note the defined centre of gravity marking as shown in **Figure 10** and **Figure 11**.

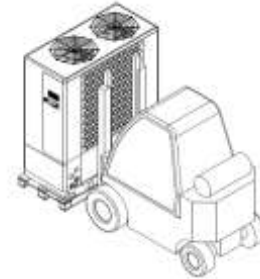
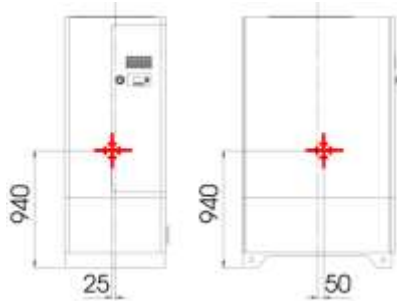

Figure 10: C6845-0 centre of gravity cBoxX 30 - 60

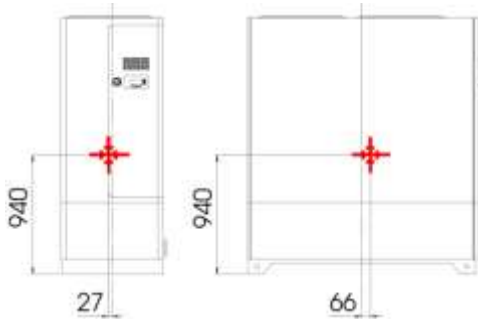

Figure 11: C6846-0 centre of gravity cBoxX 70 - 100

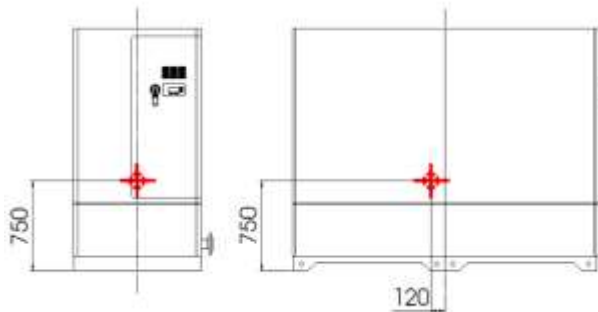

Figure 12: C6846-0 centre of gravity cBoxX 120 - 160

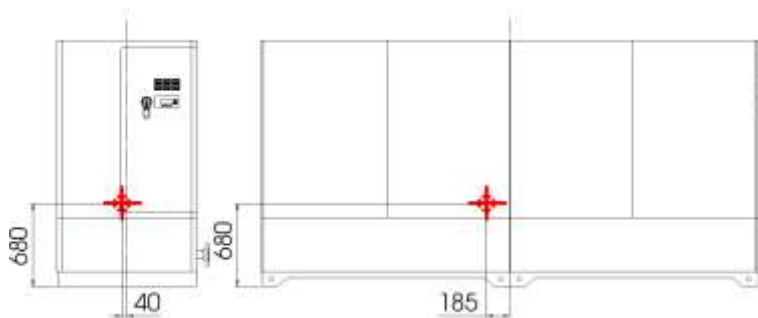

Figure 13: C6846-0 centre of gravity cBoxX 180 - 200

### 5.2.2. Crane

When it is unpacked the machine can be lifted by means of a crane and an adequately dimensioned lifting beam. **Figure 14 & 15** show the regulations for transport by crane. Please also refer to the **Table 12** for the dimensions and descriptions of the **Figure 14**.

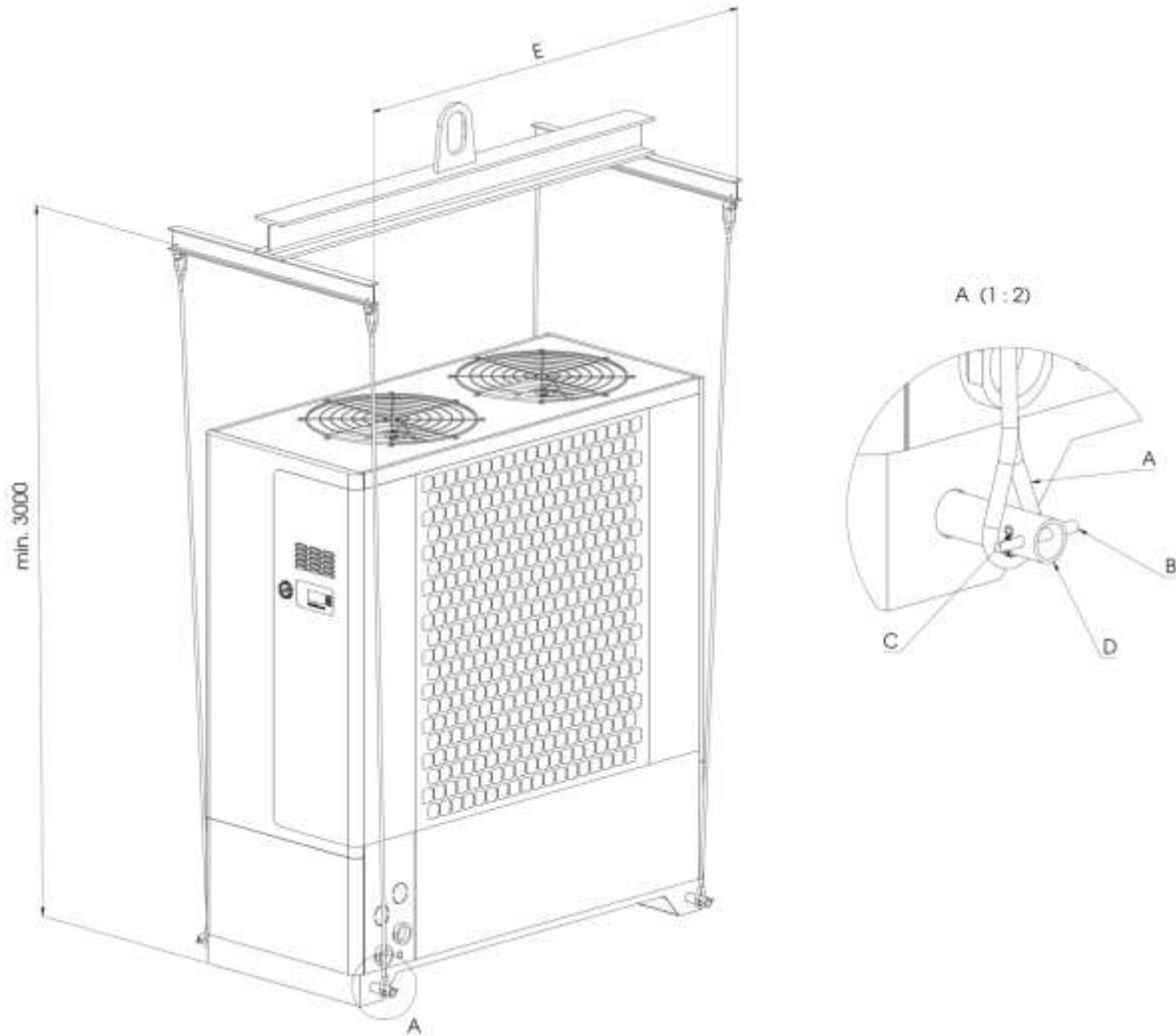
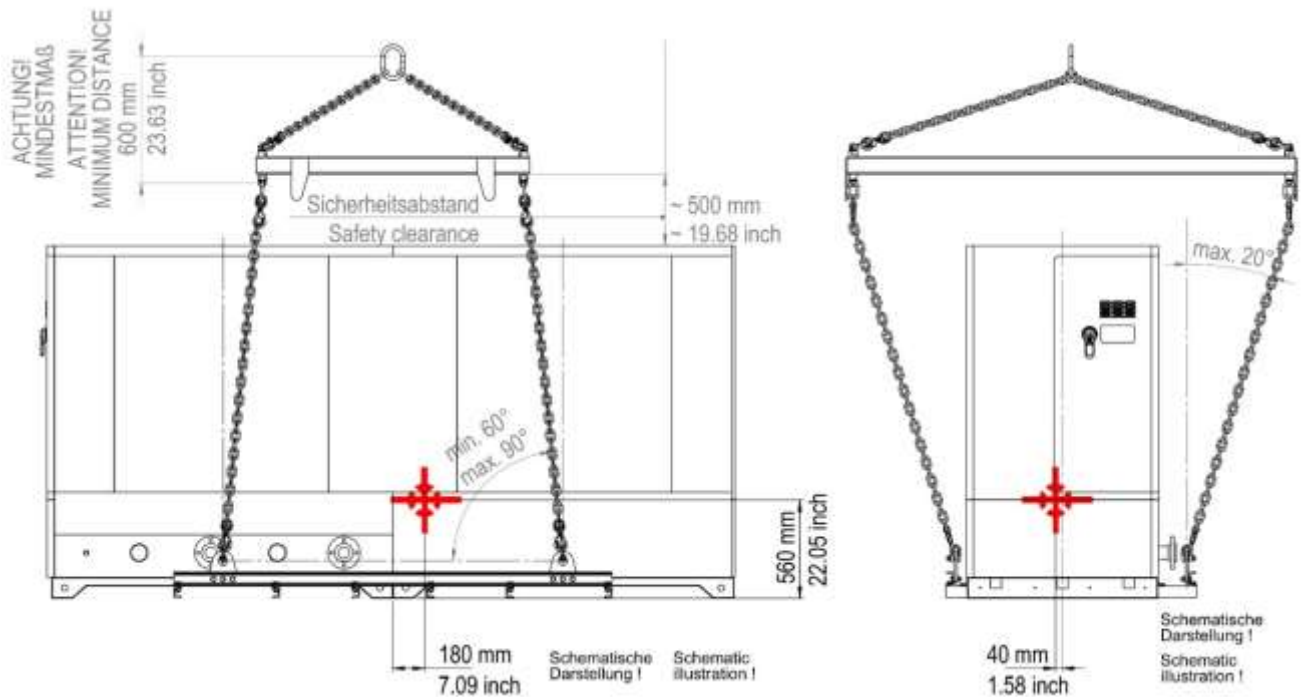

Figure 14: Crane transport cBoxX 30 - 100

Table 12: Description of figure 14

A	Transport sling or rope (do not use chains)
B	Locking bolt
C	Split rivet
D	Steel pipe diameter: 30 - 35 mm, wall thickness: min. 3 mm, length BG 1&2: approx. 1000mm
E	1300 mm (cBoxX 30 - cBoxX 60) 1900 mm (cBoxX 70 - cBoxX 100)

Figure 15: Crane transport cBoxX 120 – 200



The crane cross beam can be ordered pre-assembled ex works under the chiller (909000.0105), as well as packed loose for assembly on site (909000.0106).







### 5.3. Unpacking

	<p><b>ATTENTION! Packing straps are mechanically stressed and can snap back when cut. Risk of injuries!</b></p>
---	---

Remove all straps, films, corner protectors and spacers carefully. Optional accessories may be located under the film. Ensure that they are not damaged.

The packaging can be recycled according to the local regulations. Refer to the following table for details of the packaging materials used:

**Table 13: Materials in the packaging**

Element	Material	Recycling code
Polystyrene corner protectors	Polystyrene	
Stretch film	Polyethylene	
Edge protection / corner protectors	Cardboard	
Packaging tape	Polypropylene	
Strapping seals	Zinc-plated steel	
Wooden pallet	Untreated raw wood, spruce or pine without bark	

#### 5.4. Storage

If the chiller is stored for more than one month, it should remain in the transport packaging or be repacked.

The following conditions must be noted for storage:

- Avoid direct sunlight and moisture
- Ambient temperature - 30 °C to + 50 °C

To avoid frost damage the cold water circuit must be completely drained before the chiller is placed in storage and then flushed with a mixture of water and anti-freeze (see **11.1 Draining**).

## 6. Installation

### 6.1. Overview

Several tasks are necessary to install the chiller. The following work schedule shows the order in which they are carried out:

- Prepare the installation site
- Install the machine
- Flush the cold water circuit
- Hydraulic installation
- Fill the whole system
- Vent the whole system
- Electrical installation

### 6.2. Installation site

#### 6.2.1. General information

The chiller is suitable for indoor installation (installation site classification I) - as well as for outdoor installation (installation site classification III) for the access area categories (b) "monitored access area" and (c) "access area to which only authorised personnel have access" (note option packages).  
DIN EN 378-1

The electrical degree of protection corresponds to IP54. If installed indoors, ensure sufficient air exchange. An enclosed room will steadily heat up and the machine can switch off due to a lack of cooling. The exhaust heat from the machine can be approximately calculated as  $1.3 \times$  net refrigeration capacity. The air flow rate required for your machine is given in **Table 3 Technical data**. When choosing the installation site, ensure that waste heat from other processes cannot be guided directly onto the air intake side of the chiller.

The installation of exhaust air ducts is not permitted.



**ATTENTION! Do not install in rooms with naked flames or smoke.**

#### 6.2.2. Minimum room volume

The refrigerant R410A contained in the system is classified in safety group A1 in accordance with EN 378-1 Table E.2. I.e. the refrigerant is not flammable and has low toxicity. If the chiller is installed in enclosed rooms without additional safety measures a minimum room volume is required. This is due to the maximum concentration occurring in an area occupied by persons in the event of release and depends on the refrigerant quantity in the chiller. Please refer to the following table for the value to be complied with for your machine.

**Table 14: Minimum volume of the installation room with regard to maximum refrigerant concentration in case of a leakage if installed indoors**

cBoxX chiller	30	40	50	60	70	80	90	100	120	160	180	200
Minimum volume of the installation room (in m <sup>3</sup> )	14	14	14	16	20	20	20	20	40	40	55	55

#### 6.2.3. Ambient temperature

The chiller is cooled by the ambient air and the lower the temperature of this cooling air the more economically the chiller works. Direct sunshine or exhaust air from other machines heats up the surrounding air and must be taken into account when installing the chiller. Preference is for a shaded installation. The maximum ambient temperature is given in the technical data.

#### 6.2.4. Effect of surrounding air flow

The chiller emits heat to the surrounding area, the machine also draws in cooling air. The machine controls the quantity of cooling air automatically via the speed of the fan. Air currents surrounding the machine, such as the wind, can affect this control and endanger operation of the machine. If a constant direction of an air current is known at the installation site, this should not be directed at the air intake side of the chiller.

#### 6.2.5. Minimum clearances

The minimum clearances around the machine are made up of service clearances and clearances to ensure optimum air supply. On the one hand accessibility must be ensured from all sides, in addition, an unhindered, sufficient quantity of cooling air must be able to be drawn in and blown out upwards. If the minimum clearances are not complied with there is a risk of an air short-circuit between the air intake and discharge side. As regards to the minimum clearances please refer to *Annex III*.

#### 6.2.6. Process level

The chiller may not be installed 500 mm above or below the process level, as there is a risk of cold water escaping or running off the internal tank of the chiller. If this however is necessary, the level package option (*3.21 Level package*) must be installed.

### 6.2.7. Surface and foundation

The surface on which the machine is installed must be flat and horizontal. All the machine's feet must have uniform contact with the ground. Ensure that the ground/subsoil has sufficient load bearing capacity. According to the installation instructions (*see annex III*) a continuous concrete foundation with the given minimum size is recommended. For details, the gross weight of your machine is listed in the technical data (*Table 3: Technical data*). In the case of chillers equipped with a tank the net weight increases during operation by the quantity of liquid in the tank. This gives the gross weight.

If it is not possible to lay a foundation, the machine can also be positioned on a baseframe made of steel sections. Please also ensure here that all the unit feet have uniform contact with the baseframe.

It is recommended that the chiller be mounted on the foundation.

### 6.2.8. Stability

The normal situation is for the machine and the baseplate to be stood firmly on the ground. It is not necessary to anchor the machine to the ground. However, if this is necessary due to the surrounding conditions, the machine can be equipped with the optionally available levelling feet (**3.21 Levelling feet**). The levelling feet provide very good resistance to slipping. If this is not sufficient for your application the machine can also be bolted to the ground. Holes are provided in the machine baseplate for precisely this purpose. These are shown in *Appendix III*. The system designer is responsible for choosing suitable fixing elements.

### 6.2.9. Levelling

If it is necessary to level the chiller on the ground or floor, this can be done using the optionally available levelling feet.

### 6.2.10. Vibration isolation





If it is necessary to isolate the chiller on the ground or floor, this can be done using the optionally available levelling feet. The levelling feet are fitted with vibration-isolating elastomers.

If there is a risk of vibration transmission by adjacent machines, separate vibration decoupling is required.

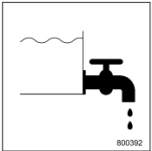

### 6.2.11. Installation

The unit-specific terminal assignment can be seen in the flow diagram enclosed with the chiller.

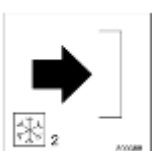
	Filling and feed (topping up)
	Draining
	Unit outlet cold water circuit 1 (supply line)
	Unit outlet cold water circuit 1 (return line)
	Unit outlet cold water circuit 2 (supply line)
	Unit outlet cold water circuit 2 (return line)

cBoxX 30-100

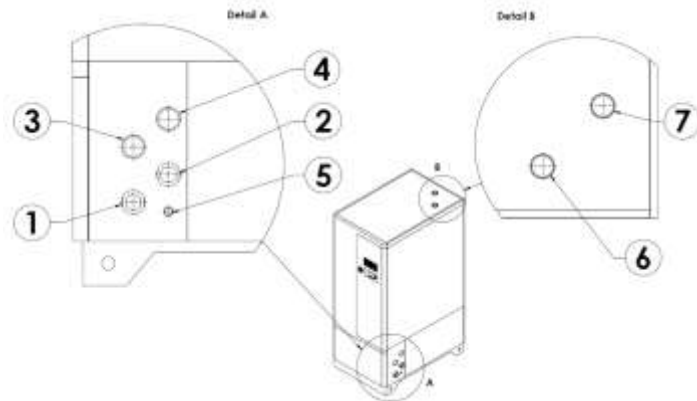

S

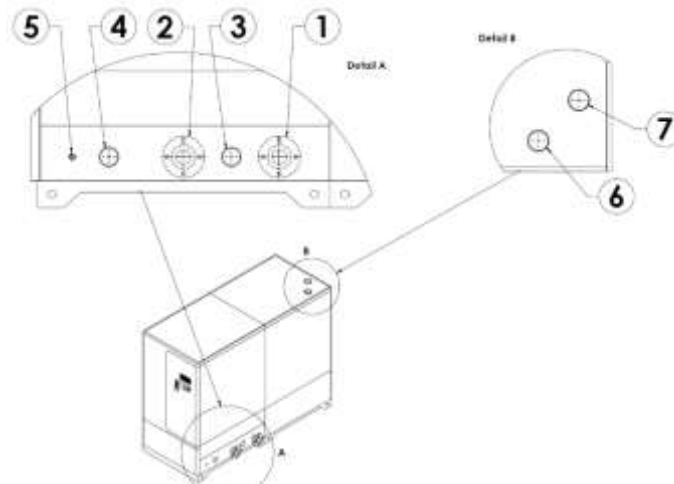

### 6.2.12. Hydraulic installation

The system designer is responsible for choosing the material and the cross-section of the hydraulic connections between the chiller and the application. Other dependent factors include the accepted pressure loss in the connection lines and the available pump pressure. When designing the connections attention must also be paid to the minimum flow rate to be maintained and sufficient resistance to the maximum pump pressure.

The insulation of the hydraulic lines, connections and fittings installed by the customer must be vapour diffusion-tight in accordance with the regionally applicable standards and regulations.

It should also be noted during hydraulic installation that the device connections on the chiller do not provide a fixed point. To avoid damage to the piping and the chiller, the hydraulic connections must be supported close to the unit connections on site.

The installation of compensators between the device connections of the cBoxX 120 - 200 and the hydraulic installation is recommended.

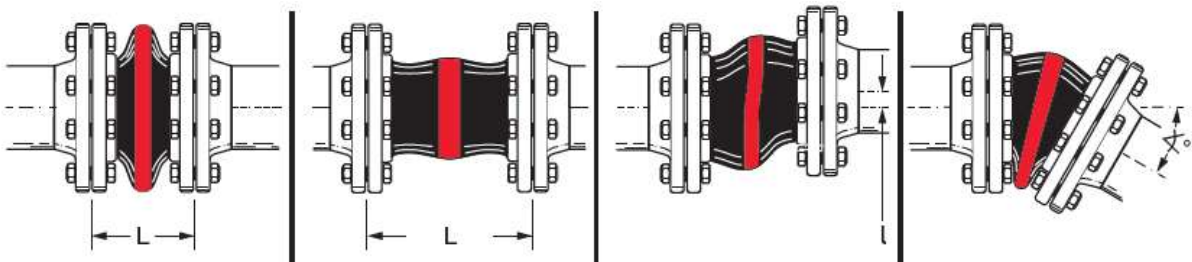

In the case of chillers equipped with an internal tank the cold water cycle must be hydraulically closed.

	<p><b>ATTENTION! Galvanised pipes must not be used if water-glycol mixtures are used! Formation of decomposition products, which result in silting up of the system!</b></p>
---	--

#### 6.2.13. Frost protection measures

The chiller is exposed to the risk of frost in two different situations. Both with an ambient temperature  $< 0\text{ }^{\circ}\text{C}$  and a feed temperature  $< 8\text{ }^{\circ}\text{C}$  there is a risk of freezing of parts of the cold water circuit system.

Installation in ambient temperature  $< 0\text{ }^{\circ}\text{C}$  with anti-freeze

The machine is protected against freezing by antifreeze. Ensure that you always comply with the requirements with regard to the operating fluid and the mix ratio. This is also valid for the version with water cooled condenser (**3.3 Version with water cooled condenser**).

Feed temperature  $< 8\text{ }^{\circ}\text{C}$

The machine must be protected against freezing by antifreeze in accordance with the specifications. Please note that the evaporation temperature is always significantly below die cold water flow temperature. Even within the supposedly safe temperature range there can still be a risk of freezing. Ensure that you comply with the requirements with regard to the operating fluid and the mix ratio.

#### 6.2.14. Flushing the cold water circuit

Contamination of external pipes and components can damage the chiller. Before the chiller is connected hydraulically with the cold water circuit this must be flushed several times. If there are dirt traps in the cold water circuit they must be cleaned after the flushing.

#### 6.2.15. Filling

If the hydraulic installation of the overall system has been completed the chiller can be filled. All shut-off valves in the cold water circuit must be opened.

	<p><b>ATTENTION! Only use approved refrigerants, see Chapter 2.17 and 2.18! If there is a risk of frost, note Chapter 6.2.14! All operating liquids must be mixed before they are added to the system!</b></p>
---	--

Procedure for chillers with integrated tank:

Remove the cladding panels 3 and 4 (see Chapter **1.2 Elements**) and fill your system via the internal filling connection mounted on the tank or use a hose to fill directly into the internal tank.

(the shut-off valve to the level sensor must also be closed and the cotter pin (if present) on the tank cap must be released)

Attention: the cotter pin (if present) must be reattached to the tank cap after filling.

	<b>ATTENTION! The spring cotter (if present) must be reattached to the fuel filler cap after filling. (flat side must point upwards)</b>
---	--



Procedure for chillers without integrated tank:

Remove the covering panel 3 and 4 (see chapter **1.2 Elements**) and fill your system with the internal filling connection above the tank (when doing so, close the shut-off valve leading to the level sensor). It is also possible to fill directly into the tank by using a hose.

All filling and feed connections are identified with the following pictogram:



Figure 16: Filling and feed connection

	<b>ATTENTION! In the EU you must follow the provisions of EN378-3. Please also note and follow the local installation regulations and provisions, especially the Ordinance on handling water pollutant substances and BGR500 Chapter 2.35.</b>
---	--

### 6.2.16. Venting

If your chiller contains a horizontal pump (standard for cBoxX 30 – cBoxX 100), the pump does not have to be vented. If your chiller contains a vertical pump (standard for cBoxX 120 – cBoxX 200) the pump has to be vented. To do this, before switching on the pump the vent plug must be opened and left open while the unit is running until all air has completely escaped from the pump body (see *Figure 17*).





Pump venting  
(here: open-ended spanner SW9)

**Figure 17:** Position of the pump vent (vertical type)

If your chiller is equipped with an internal tank, further water circulation ensures that the residual air in the overall system can escape into the atmosphere via the open tank.

For machines without a tank we recommend installing an automatic venting valve at the highest point in the cold water circuit.

### 6.2.17. Electrical installation

	<p><b>ATTENTION!</b> The electrical installation, testing and commissioning may only be carried out by qualified personnel. Note and follow the local regulations.</p>
	<p><b>ATTENTION!</b> Do not switch on the chiller until the hydraulic installation is completed and the machine has been filled as specified in Chapter 6.2.15. Otherwise the machine could be damaged.</p>
	<p><b>ATTENTION!</b> The mains voltage must comply with the quality features of EN 50160 and the defined standard voltages of IEC 60038.</p> <p>The electrical connection on the building side is the responsibility of the operator.</p> <p>The operator must ensure that the permissible limit values in DIN EN 60204-1 (occurrence of a leakage current to earth at any mains connection of more than 10 mA AC or DC) are complied with, and that measures are taken to reduce them to non-critical values if they are exceeded.</p>

The chiller is connected electrically to its main supply terminal in the control cabinet. (see *Figure 18 Main supply*). A circuit diagram is supplied with the unit.

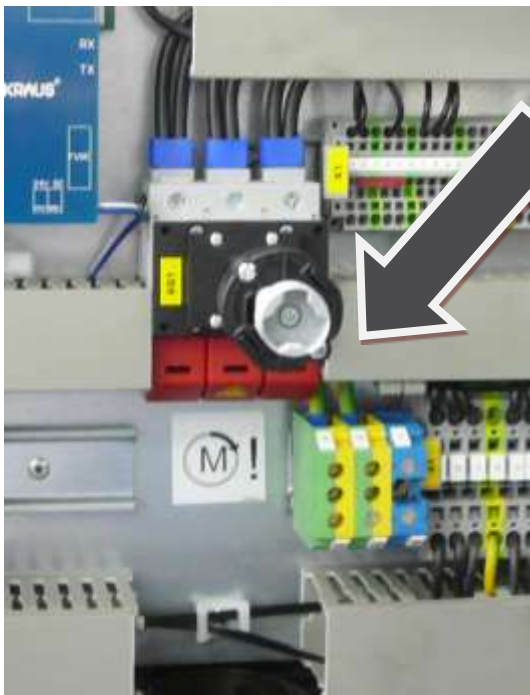

Figure 18: Main supply

The dimensioning of the load cable and the fusing must be in accordance with the machine's technical data and the local regulations of the power supply company.

The supply cable must be routed into the machine. Cut-outs are provided for this purpose in the baseplate and in the compressor mount (cBoxX 30 – cBoxX 100). Feed the supply cable, protected by rubber grommets, through these openings (*see Figure 18 Main supply*). Please note that the dimensions described in DIN VDE 0298-4 must be observed.

Never switch on the chiller immediately if the machine is moved from a cold into a warm room. The condensing moisture can damage electronic components. For the initial startup or following a lengthy period out of use all the electronic components must have become acclimatised.

Make use of an external control line to set the release (see *Chapter 8.3 External release*) of the chiller. This must be laid separately from the supply line and wired to the corresponding terminals in the control cabinet. (see circuit diagram enclosed in the unit)

Once the electrical installation has been completed the phase sequence must be tested. This is done by checking the rotational direction of the pump. This has a rotational direction arrow on it. If the rotational direction does not match the arrow, the phase sequence can be corrected by swapping two phases at the main supply.

## 7. Commissioning

Before commissioning the chiller the checklist must be used to check whether all the necessary work in **Chapter 6 Installation** has been carried out properly.

The chiller must be installed for at least 12 hours at  $>+5\text{ }^{\circ}\text{C}$ , so that the compressor oil can heat up and the refrigerant can be liberated from the oil.

If your machine is equipped with oil sump heating and the machine has been completely installed, it is permissible to switch on the machine at the main switch and to allow the compressor to be preheated for at least 3 hours without enabling the cooling.

### 7.1. Installation checklist

- The device has been set up for at least 12 hours at  $>+5\text{ }^{\circ}\text{C}$ ?
- Unit installed horizontal and stable?
- Any vibration damping and floor anchors installed?
- Spaces / clearances around the unit are adequate according to the requirements?
- Air intake side free from packaging materials, etc. ?
- Hydraulic connection OK?
- Cold water circuit filled in accordance with the specifications? Water quality OK?
- Whole system flushed? Dirt trap cleaned?
- Cross-sections adequately dimensioned?
- Electrical connection OK? Electrical power is available?
- External pumps OK? Rotational direction?
- Unit cover closed?
- Overall system OK and ready for commissioning/startup?
- Compressor "preheated" ?
- External enable OK?
- System checked for leaks OK?

After checking the above list you can continue with **Chapter 8 Operation**.



## 8. Operation

The chiller is designed for fully automatic operation.

### 8.1. Switching on

First, switch on the machine at the main switch (component 5 in *Figure 19: C6842 Display elements and controls*). The Start screen appears on the display.

### 8.2. Selecting the operating mode

In the Start screen you can choose between the following three operating modes:

- **Standby:** This operating mode must be selected if the chiller has been without power for more than 6 hours at ambient temperatures  $<5^{\circ}\text{C}$ . In this case the compressors must be preheated for 3 h, so that the refrigerant can escape from the oil. The crankcase heater and thermostatic pump start are effective.

**Auto:** The chiller is ready for operation. Fully automatic operation starts by means of external approval (potential-free contact) according to *Chapter 8.3 External release*. When the contact is open, the crankcase heater and thermostatic pump start are effective. When the contact is closed, fully automatic control of the compressor and the tank heater is enabled. The chiller regulates to its setpoint.

- **On:** The chiller is permanently switched on in fully automatic operation without external release.

### 8.3. External release

In the delivered state the contact for the external release is bridged. An external control cable can be wired up in place of the bridge. Refer to *Chapter 6.2.17 Electrical installation* Information on installing External Approval. Fully automatic operation starts with this external release.

### 8.4. Control

The chiller's control consists of a control board and a control panel, which communicate with each other via a BUS connection. The control board operates autonomously so that if the control panel or communication fails, operation continues to be possible if no other fault prevents operation.

The program, setpoints, parameters and times are stored in an EEPROM in the controller and are therefore retained even in the event of a power failure. Therefore the control does not require a buffer battery. The buffer battery is only used to keep the clock running.

## 8.5. Control panel

The following **Figure 18** shows the chiller's display elements and controls.

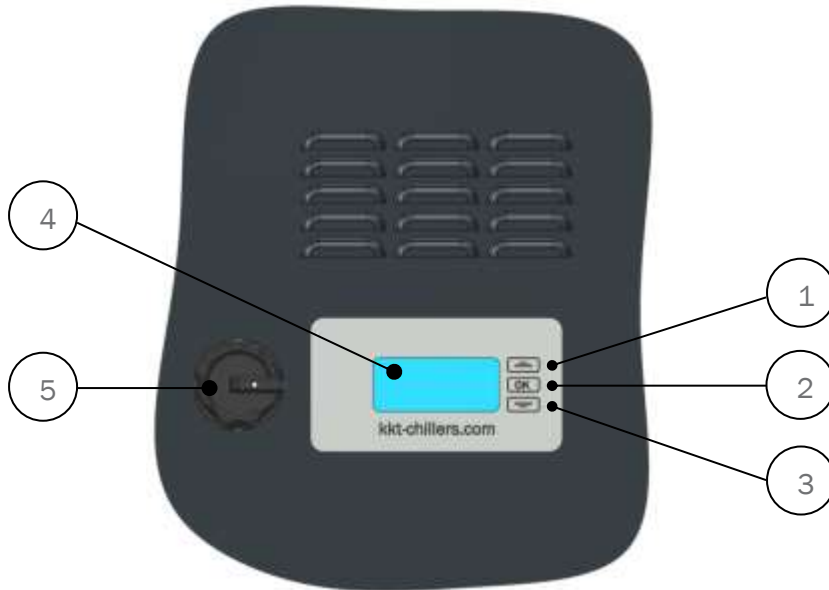

Figure 19: C6842 Display elements and controls

Table 15: Description of C6842

Number	Function Key	Function
1	"UP" button	Navigation button
2	"OK" button	Navigation button & acknowledgement button for warning and fault messages
3	"AB" button	Navigation button & acknowledgement button for warning and fault messages
4	Display with plain text	
5	Main switch	

Use the "UP" and "DOWN" buttons to select the required menu item. The selected menu item is displayed with inverse text. Press the "OK" button to return to or exit the selected menu. The data is accepted at the end of the menu by selecting the box with the tick/checkmark. In the Start screen the "right" arrow points towards the Main menu. The "left" arrow indicates return to the previous menu.

The displays are divided into two access levels:

- Customer
- Factory

Detection occurs by means of a USB stick or day password. Only the information that exists or is selected in the configuration is displayed.

### 8.5.1. Start screen



Figure 20: Start screen with tank and without alarm

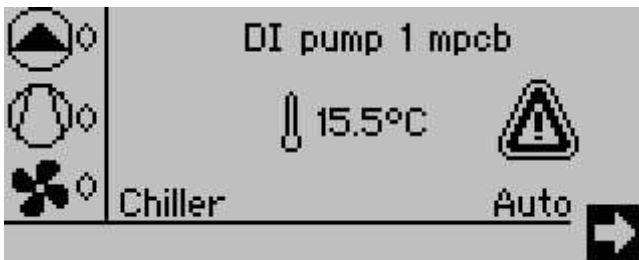

Figure 21: Start screen with alarm

The general operating state of the chiller is displayed on the Start screen:

- Active alarm
- Top left-hand side: Number of pumps running
- Left-hand middle: Number of compressors running
- Bottom left-hand side: Number of fans running
- Middle: Actual value of the cold water feed
- Right-hand side: Tank level (if tank installed)

If an alarm is active the alarm symbol is displayed

Press UP, DOWN and UP to switch to the selection fields, in which the Time - Date setting, the menu access arrow as well as the operating status selection are located. There are three switching commands:

- STANDBY: the chiller is always switched off
- AUTO: the chiller is switched on and off via the potential-free contact.
- ON: the chiller is always switched on

### 8.5.2. Main menu



Figure 22: Main menu

From the Main menu you can move into the submenus or return to the Start screen.

### 8.5.3. Information

In the Information menu you can move into various submenus to obtain an overview of the state of the chiller.

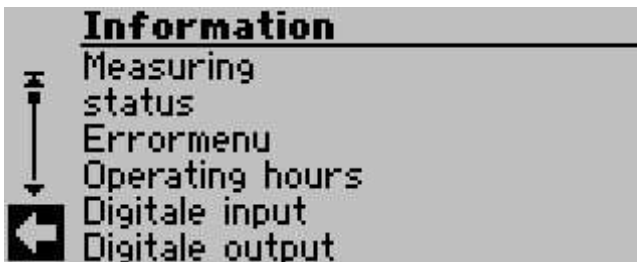

Figure 23: Information

In the Measured Value (Readings) menu you can call up the values of the analog inputs.

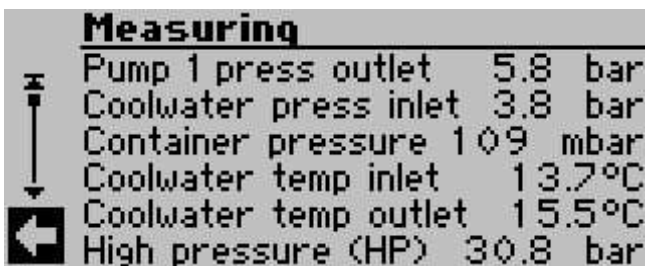

Figure 24: Measured Value menu

In the Status menu the states of the digital inputs and outputs and several internal control states can be called up.

<b>status</b>		
↑	DI resetswitch	Off
↓	DI remotecontrol	On
↓	DI 3-phases	Off
↓	DI pump 1 mpcb	On
←	DI compressor 1 mpcb	Off
←	DI HP delimiter	Off

Figure 25: Status menu

The alarms are listed in the Alarm menu. A detailed description is given in Chapter **8.5.5 Alarm menu**.

The operating hours counter gives information on the operating hours of the individual components and cannot be reset.

<b>Operating hours</b>		
	DO pump 1	2 h
	DO compressor 1	2 h
	DO compressor 2	0 h
	DO compressor 3	0 h
←	DO compressor 4	0 h

Figure 26: Operating hours counter

The digital inputs shows the state at the terminals of the digital inputs.

<b>Digitale input</b>		
↑	DI1 clip 1,2	On
↓	DI1 clip 3,4	Off
↓	DI1 clip 5,6	On
↓	DI1 clip 7,8	On
←	DI1 clip 9,10	On
←	DI2 clip 1,2	On

Figure 27: Digital inputs

The digital outputs show the state of the output relays.

<b>Digitale output</b>		
↑	DO1 clip 1,2	On
↓	DO1 clip 3,4	Off
↓	DO1 clip 5,6	On
↓	DO1 clip 7,8	On
←	DO2 clip 1,2	Off
←	DO3 clip 1,2	Off

Figure 28: Digital outputs

The analog inputs show the signal upstream of the analog digital converter. The value must be between 0 and 4095. 0 means that no sensor is connected. 4095 means that the input is short-circuited.

<b>Analog Input</b>		
↑	AI1 clip 1,2	1952
↑	AI2 clip 1,2	1936
↑	AI2 clip 3,4	2233
↑	AI2 clip 5,6	1882
←	AI3 clip 1,2	2252
←	AI3 clip 3,4	2342

Figure 29: Analog inputs

The analog outputs show the signal upstream of the digital - analog converter. The value 10000 corresponds to an output voltage of 10 volts.

<b>Analog Output</b>		
↑	A01 clip 1,2	0
↑	A01 clip 3,4	0
↑	A01 clip 5,6	10000
↑	A01 clip 7,8	4502
←	A02 clip 1,2	7000
←	A02 clip 3,4	8000

Figure 30: Analog outputs

#### 8.5.4. Settings

All setpoint/target and parameter values and times are stored in the Settings menu.

<b>Settings</b>	
	Limit monitoring
	Controlling
	Controlling pump
	Controlling compressor
←	Chillerconfiguration

Figure 31: Setting

### 8.5.5. Alarm menu

The alarm is acknowledged if the "OK" button is pressed for longer than **eight** seconds.  
(after five seconds, the display switches back to the start menu)

- active: The alarm is still active. (e.g. DI MSS ...) The motor protection switch has triggered.
- OK: The alarm is no longer on and has been acknowledged on the control panel. The alarm entry no longer appears the next time the Error menu is called up.
- SH: The alarm is no longer queued. E.g. the motor protection switch has been unlocked on the hardware side but has not yet been acknowledged at the control panel.

Alarms that are preceded by the abbreviation DI refer directly to the digital input. All digital inputs must be closed in a fault-free state. The abbreviation AI indicates a sensor error of an analog input. The analog input must be checked for interruption and short circuit. Alarms without abbreviations are formed internally in the control.

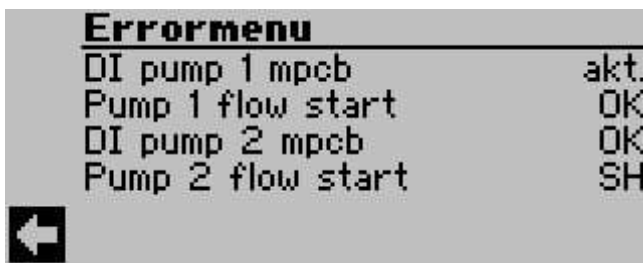

Figure 32: Alarm menu

### 8.6. Parameters

The parameters are divided into the three display and access levels:

- Customer, user
- Service

A parameter can have a lower display level than access level. I.e. not all the parameters displayed can be changed.

The specific parameter list for your application is enclosed with the unit.

## 8.7. Controller description

### 8.7.1. Thermostatic pump start

To save energy, the consumer pump is not operated permanently, but cyclically. An evaporator pump, if present, is also controlled. The tank heater or compressor is released after a short circulation of the cold water.

The thermostatic pump start is intended for two applications:

1. When the chiller is switched on, a defined "start" temperature of the cold water should be made available to the application. The water temperature is kept at a constant level to prevent unnecessary temperature drops or increases.

= **Pre-tempering**

2. If the system is not installed without anti-freeze mixture in the cold water circuit, a minimum temperature of 5 °C should be maintained.

= **Anti-freeze mixture**

The tank heater is activated when the temperature falls below the minimum setpoint and the compressor is activated when the maximum setpoint is exceeded. A separate hysteresis is assigned to each setpoint.

This results in the following control sequence:

- Cyclic activation of the pump every 60 min. for at least 5 min.
- 1 min. after activating the pump (circulation process), the tank heater or compressor is released.
- The pump switches off when the runtime has elapsed and the tank heater and compressor are no longer required by the temperature.

If the interval time is 0 min, the thermostatic pump start is only activated via the temperature. However, the runtime is effective.

### 8.7.2. Electronic level monitoring

Before switching on the chiller the electronic level monitoring starts up.

The level is monitored for three states:

- Tank min level STOP; the chiller switches off immediately.
- Tank min level warning; the chiller continues running but does not switch back on in the event of a stoppage. The water feed solenoid valve (only with optional automatic water top-up) is opened.
- Tank max level message; the cold water feed, water feed solenoid valve (only with optional automatic water feed) is closed.

The ideal state is if the level is above the warning level and below the maximum level. In this case no message appears.

If the chiller is switched on and the min level warning is reached the chiller remains switched on so that any cooling process that has been started is not interrupted. If the chiller is switched off, the chiller does not start, to ensure that no cooling process is initiated that may not be able to be ended.



### 8.7.3. Switching the chiller On/off

The following conditions must be fulfilled for the chiller Standby state:

- The control has completed its initialization routine,
- Release of at least one primary pump,
- Release of the cold water feed or return sensor,
- No exceeding of the cold water feed temperature,
- Release through tank level monitoring,
- Approval by cold water pressure monitoring on evaporator.

A primary pump is released if:

- It is selected in the system configuration of the software,
- No motor protection switch faults are queued,
- No flow monitoring faults are queued,
- No minimum or maximum pump pressure faults are queued.

A condenser fan is released if:

- No motor protection switch faults are queued,
- No fault is queued at the digital fault input (e.g. control unit group fault).

From the standby state, the chiller can be switched on or off via a software switch in the display. In Automatic mode the floating contact for the remote control must be closed.

When the system is switched on the primary pumps are switched on with a 3.5 s delay. After a further 3.5 s the fan control is released.

When the primary pump is switched on a timing element starts for each pump, which activates the monitoring of the minimum and maximum cold water pressure at the pump outlet. When the pump is switched on a timing element also starts for release of the compressor's temperature control. The compressor's temperature control is released when the time of a pump has expired. This time is also used for activation of the flow monitoring.

The pressure and flow monitoring takes place with two timing elements:

- Delay at start; the pressure or the flow monitoring does not trigger an alarm.
- Delay during operation; in order to ignore short-term fluctuations in pressure or flow, the alarm is delayed.

When the system is switched off the temperature control is locked immediately and therefore the compressor is switched off. The pump continues running to prevent uncontrolled continued evaporation.

#### 8.7.4. Cold water flow temperature control

In the normal case the sensor in the tank (system with tank, with pump) is used to control the cold water feed temperature. If this sensor fails, the control switches internally to the sensor in the cold water return and the target value (setpoint value) is increased by a defined value.

A purely proportional controller is used, which generates an output signal from -100 % to +100 %. The switching on and switching off points of the cooling levels are set within this range. If the setpoint is changed the switching ratio between the compressors is retained, it is shifted overall. If the proportional range is changed the switching ratio is also retained. The range is extended or reduced.

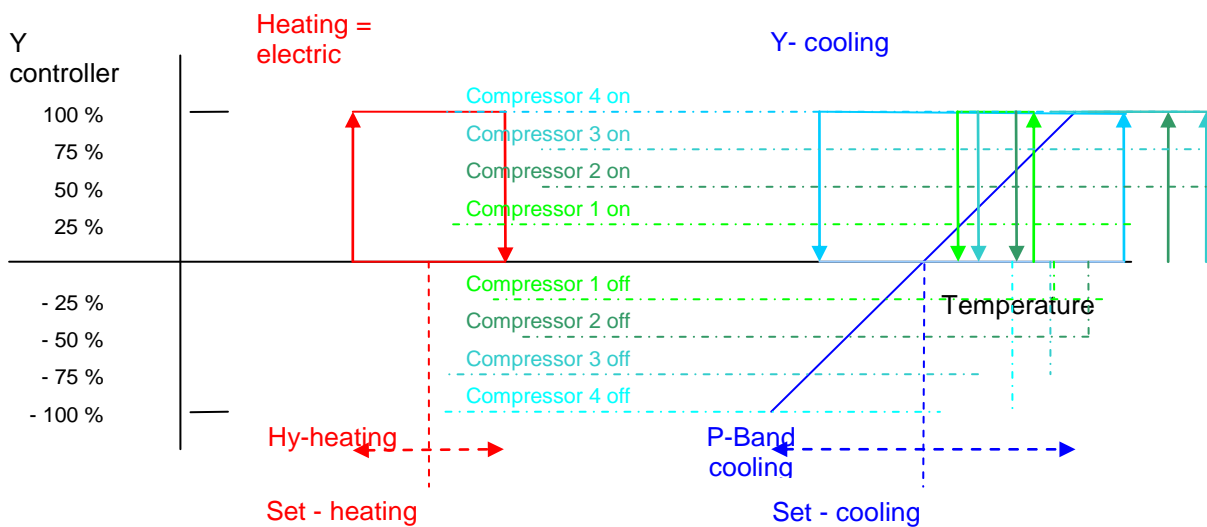

Figure 33: Cooling and heating sequence

Different operating states reduce the number of cooling levels required by one cooling level:

- High pressure warning
- Low pressure warning
- Difference between high and low pressure is too large.

#### 8.7.5. Compressor control

The control is defined for a refrigeration circuit with a maximum of four compressors. The number of compressors is selected by means of coding resistance. The number of compressors is determined once when the control is restarted (switching on of the operating voltage) and is compared with the number of the last restart. If these are not the same the "Coding resistance changed" alarm is generated. When the alarm is acknowledged the new number of compressors is stored in the E-EEPROM and the factory setting is accepted as the new number of compressors.

The compressors are requested depending on the controller output signal. The compressor with the least number of operating hours switches on first. If no more refrigerating capacity is required the compressor that switched on first also switches off first. The compressors are switched on with a time delay (comment: only applies if several compressors exist)

In the event of a fault in a compressor (motor protection switch) a fault changeover is activated. The high pressure is monitored on the hardware side by means of the high-pressure limiter. If it is triggered all compressors switch off immediately. In addition, the high pressure is controlled by means of a pressure transmitter. This also switches off the compressors if the setpoint is exceeded, but releases them again if the value falls below the release value. Before switching off the, high-pressure transmitter signals a warning.

Low pressure is also monitored by pressure transmitters. If the value falls below the setpoint the compressors switch off. If the switch-off value is exceeded by the hysteresis, the compressors are released again. The triggering of the alarm is delayed by two timing elements. The first timing element is started with the request for the compressor. If no intake pressure has built up by the time the time expires the low-pressure fault alarm is triggered. After the start time has expired the low pressure may exceed the switch-off value for a short time. If this occurs more than three times within an hour the compressors are blocked. Before a low-pressure fault is triggered a low-pressure warning is signalled.

#### **8.7.6. Fan speed control**

Due to the continuous adjustment in the number of fans, the condensing pressure is kept constant depending on the ambient temperature by means of a PI controller. As the condensing pressure at the moment in which the compressor is switched on rises very fast, the PI controller is superimposed by a P controller with limiting setpoint. This only intervenes if the PI controller is too slow.

#### **8.7.7. Electronic expansion valve control**

An electronic expansion valve with PI controller is used to keep the overheating constant. To prevent the maximum operating pressure (MOP) from being exceeded, a P controller is used, which counteracts when the MOP is approached and limits opening of the electronic expansion valve.

#### **8.7.8. Temperature limit monitoring**

The temperature of the cold water feed is monitored for a minimum and maximum limit value if the chiller is switched on (pump is running). If the limit value is exceeded or the minimum is not reached, an alarm is triggered with time delay, which switches off the chiller.

#### **8.7.9. Group fault alarm**

A group fault alarm is triggered if an alarm occurs. All alarms are included in the group fault, but not the warnings. The group fault signalling relay has a floating changeover contact and is energised in fault-free operation, in order to ensure wire break monitoring.

## **8.1. Execution types**

Basically, you can choose between two types of construction:

### **8.1.1. ECO mode**

The default setting of the Compact-Line provides for operation in ECO mode ("Run" parameter is set to "0"). As a result, the increase in fan speed reduces the condensing pressure to the minimum necessary value in the respective operating point – the electrical power consumption of the overall system is limited to a minimum.

### **8.1.2. Comfort mode**

In case of strict sound emission requirements the fan speed can be reduced to the minimum necessary value in the respective operating point and sound power level limited to a minimum. To do this the "Run" parameter must be set to "1". As a result of the lower air flow rate a reduced output of around 3% is to be expected.

The optimised parameter list for your application is enclosed with the unit.

## 9. Cleaning

### 9.1. Air filter mat

To maintain high performance the optional air filter mat (**3.19 Air filter mat**) must be checked for contamination at least once a month. The correct air filter mats can be ordered at any time as an original spare part – please contact our KKT chillers Service Team (**Table 1 Contact details**).

### 9.2. Condenser

To maintain high performance the microchannel heat exchanger must be cleaned if there is any visible contamination, but at least annually. To do this, disconnect the unit from the power supply and remove the service panels and the condenser protective grille (panels 3 and 5, see Chapter **1.2 Elements**). First of all, remove coarse dirt particles from the outside using a standard vacuum cleaner. Then flush the microchannel heat exchanger carefully, in the opposite direction to the air flow, from inside with warm tap water. Then clean with a wet vacuum cleaner until the surface is dry again. For versions with water cooled condensers see complete cleaning of the cold water circuit.

### 9.3. Water filter

If the existing water quality (dirt load) Chapter 2.17 Water quality as well as the required water circulation quantity differ, a water filter must be used. (**3.23 Filter assembly group coolant**) It must be checked for contamination at least once a month. The appropriate filter unit can be ordered as an original spare part at any time – please contact our KKT chillers Service Team for this (**Table 1 Contact details**).

### 9.4. Complete cleaning of the cold water circuit

Due to the complexity and diversity of the possible external materials, we recommend that the complete cleaning of the cold water circuit only be carried out by qualified personnel – please contact our KKT chillers Service Team (**Table 1 Contact details**).

## 10. Service

All service work may only be carried out by properly trained, competent personnel.

### 10.1. Maintenance

Reliable operation and a long service life for the entire system can be guaranteed by proper maintenance.

The purpose of the maintenance is:

- to ensure that the machine operates reliably and without unexpected failures
- to plan further service work in order to minimise downtimes

An overview of the maintenance intervals as recommended by the VDMA is given in **Appendix II**. In addition, the national regulations of the respective installation site must be followed.

Please note that the points listed represent the minimum maintenance required. By increased monitoring, system reliability can be enhanced. Please contact our service department at any time about maintenance quotations / service agreements.

### 10.2. Fault correction

Troubleshooting and fault correction instructions are given in **Appendix IV**.

Our technical customer service can be reached around the clock and will assist you with all service matters (maintenance, repairs, spare parts, etc.):

Europe Service Team  
T +49 9228 9977 7190  
E [service@kkt-chillers.com](mailto:service@kkt-chillers.com)  
W [www.kkt-chillers.com](http://www.kkt-chillers.com)

USA Service Team  
TF +1 866 517 6867  
E [support@kkt-chillersusa.com](mailto:support@kkt-chillersusa.com)  
W [www.kkt-chillersusa.com](http://www.kkt-chillersusa.com)



### 10.3. Spare parts

To ensure that the performance of your chiller is not impaired, we recommend that you only use original spare parts purchased from KKT chillers. In this way you ensure the reliability and quality of the machine. For spare parts enquiries, please contact our KKT chillers Service Team [spareparts@kkt-chillers.com](mailto:spareparts@kkt-chillers.com) or (**Table 1 Contact details**).

## 11. Taking out of service

	<p><b>ATTENTION! Decommissioning must only be carried out by professional and qualified technicians.</b></p> <p><b>They must also be familiar with the local regulations.</b></p>
---	---

For safety-relevant instructions regarding possible residual energy, please refer to **Chapter 4.3 Residual energy**.

### 11.1. Draining

If the system is filled and there is a risk of frost, suitable measures must be taken to protect the liquid from frost. The complete cold water circuit must be fully drained before any lengthy stoppage of the unit. Do this as follows:

1. Drain the tank via the drain cock provided  
(when doing so, close the shut-off valve leading the level sensor)
2. Drain the evaporator via the drain cock provided
3. Drain the pump using the drain plug provided

The drain cock is marked on the unit by the symbol in **Figure 34**.

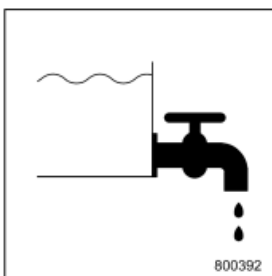
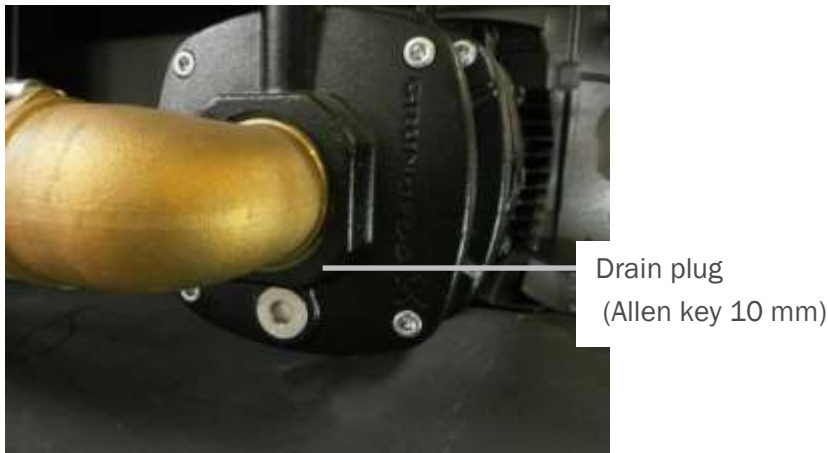

Figure 34: Labelling of the drain cock

The position of the drain plug is shown in *Figure 35*.



**Figure 35: Position of the pump drainage (horizontal type)**

To prevent frost damage the cold water circuit must then be flushed with a mixture of water and 40 % by vol Antifrogen-N (or equivalent).

## 12. Recycling

	<p><b>ATTENTION! Dismantling must be carried out by professional and qualified technicians.</b></p> <p><b>Water and refrigerant pipes are pressurised!</b></p> <p><b>They must also be familiar with the local regulations.</b></p>
---	---

All parts (e.g. refrigerant, oil, glycol, metal, electronics, battery etc.) must be recycled, reused or disposed of. Please note and follow all local and national regulations and if necessary contact your local waste management agency.

A specialised disposal company must be contracted to dispose of these wastes. They issue a proof of disposal which must be archived. The chiller can be returned to KKT chillers for disposal. Please contact our KKT chillers Service Team for details (*Table 1 Contact details*).

## 13. Products, solutions and services

Apart from the Compact-Line, KKT chillers also offers other products, solutions and services which are not described in this document. For more information, visit our homepage <http://www.kkt-chillers.com> or contact your KKT chillers contact (*Table 1: Contact details*)– we look forward to hearing from you!



I. Main dimensions

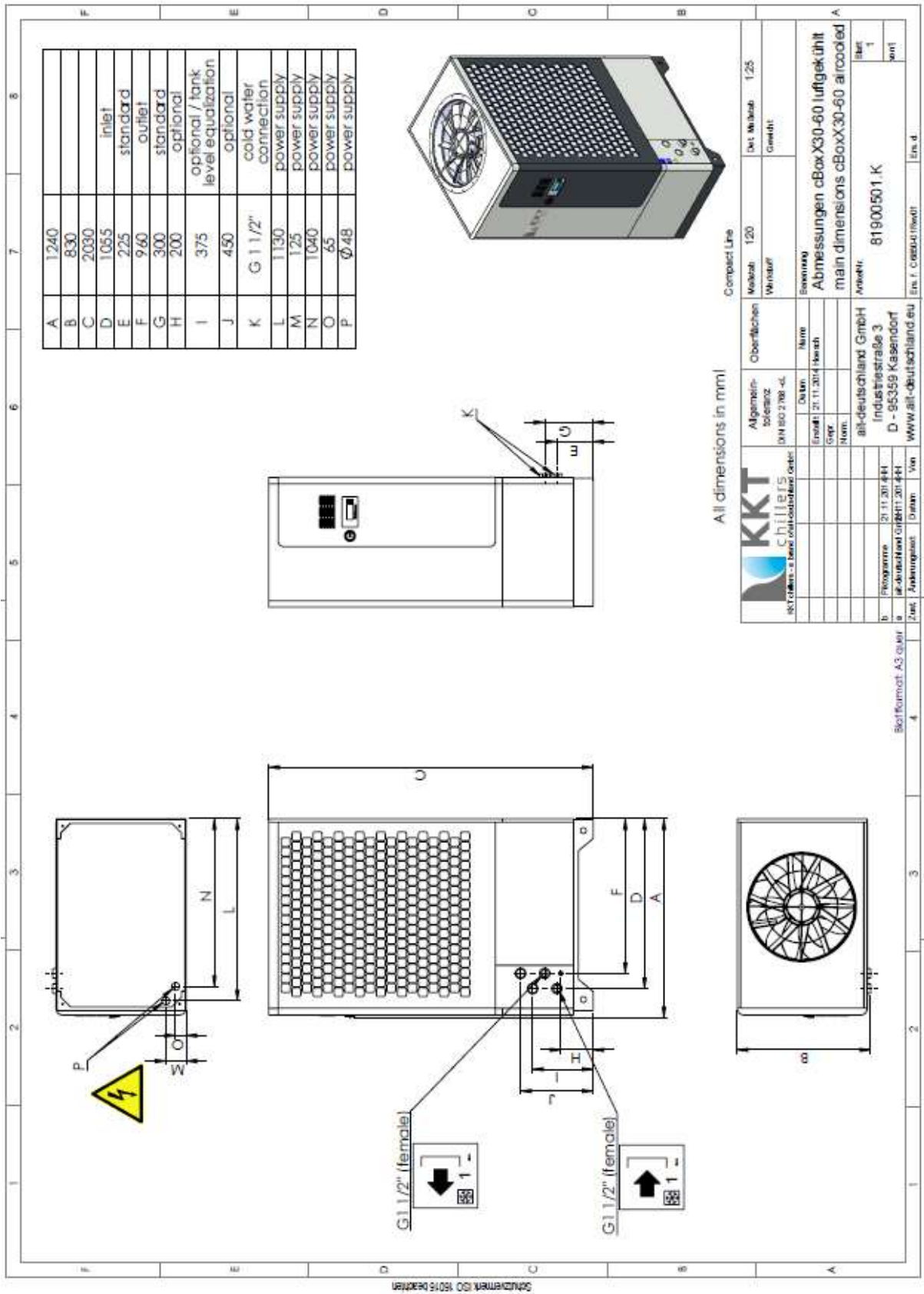

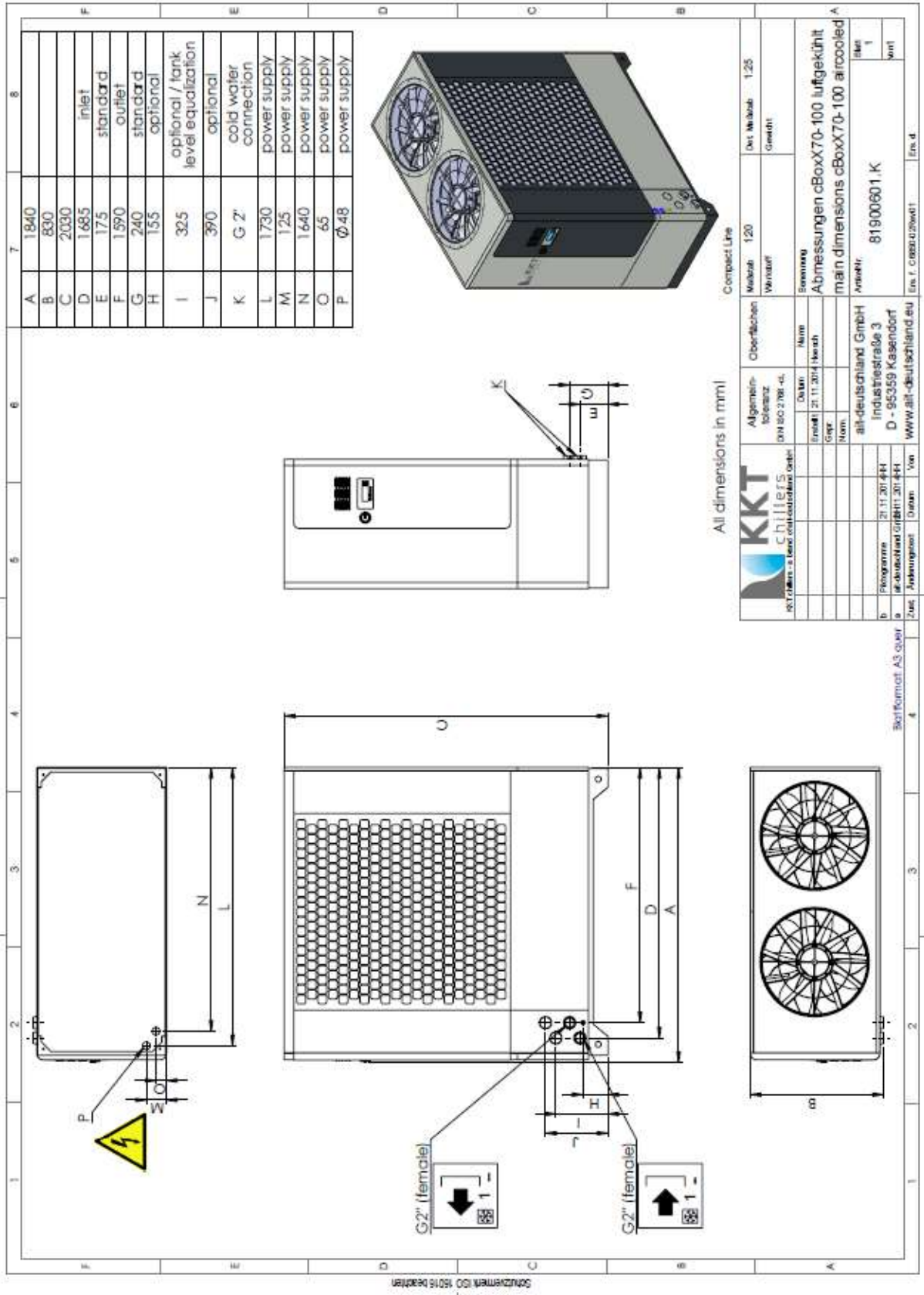

A	1840
B	830
C	2030
D	1685
E	175
F	1590
G	240
H	155
I	325
J	390
K	G 2'
L	1730
M	125
N	1640
O	65
P	∅48

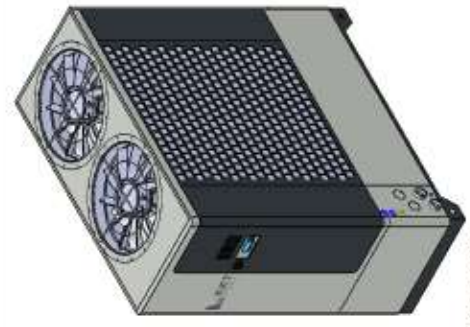

All dimensions in mm)

Compact Line	
Modell	120
Hersteller	Greecht
Oberflächen	
Material	120
Genauigkeit	1,25
Allgemein- toleranz DIN ISO 2768- mS	
Druck	Norm
Temperatur	Norm
Umweltbedingungen	Norm
all-deutschland GmbH Industriestraße 3 D - 95359 Kasendorf www.all-deutschland.eu	
Programme	21.11.2014-44
Druck	21.11.2014-44
Zust.	Änderungen
Von	Datum

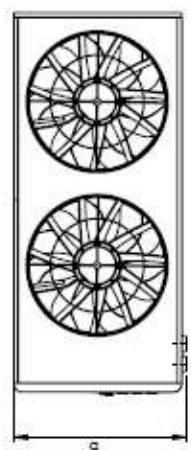

Schweizerwerk ISO 15018 beachten

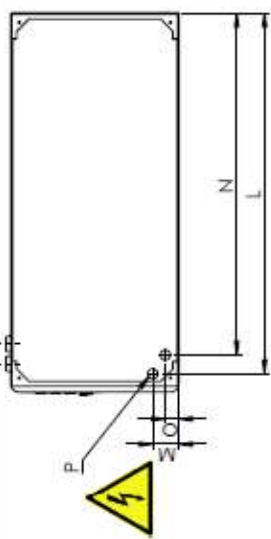
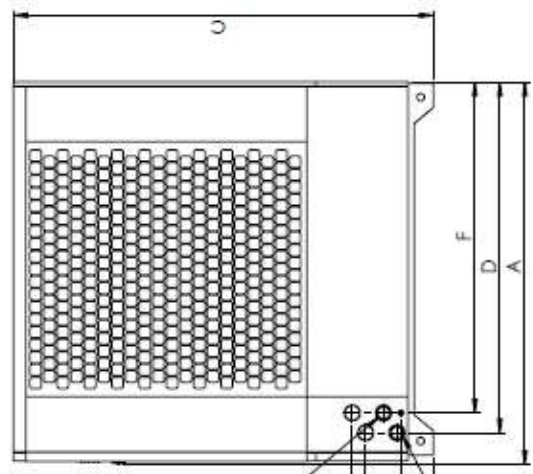
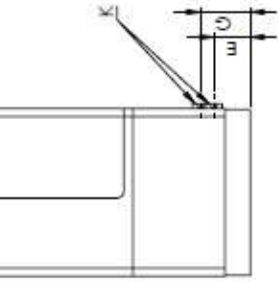

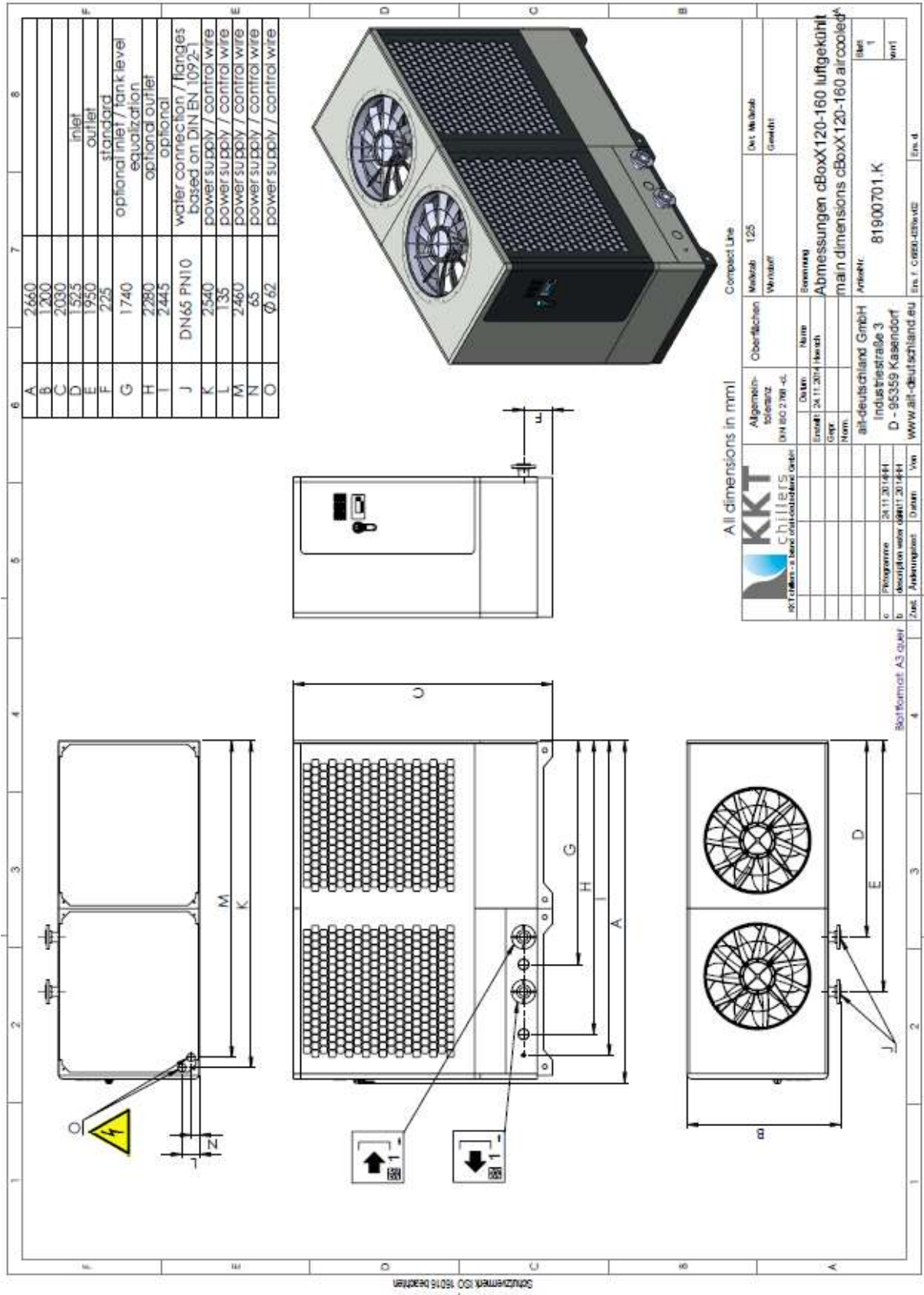



## II. Installation instructions

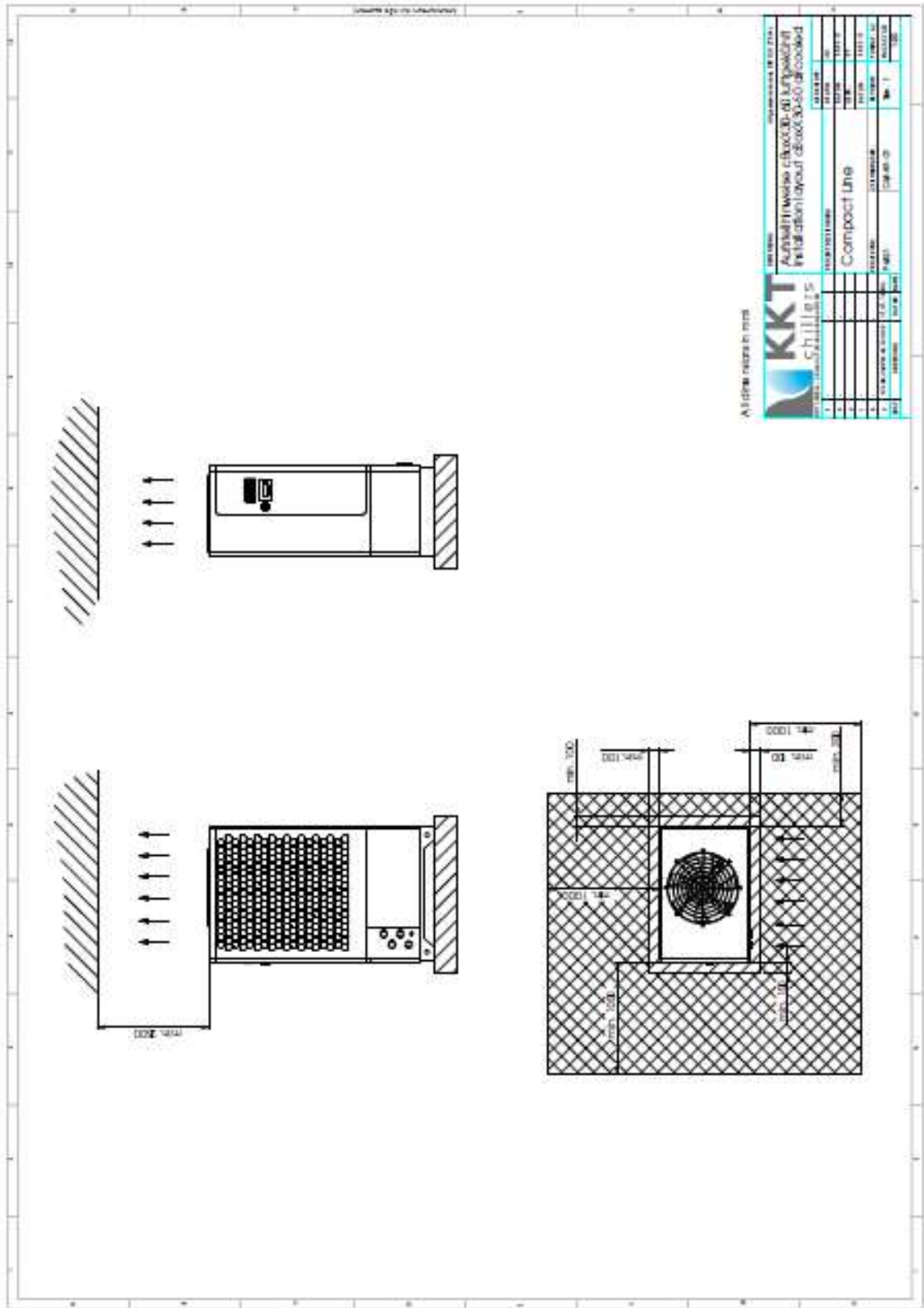

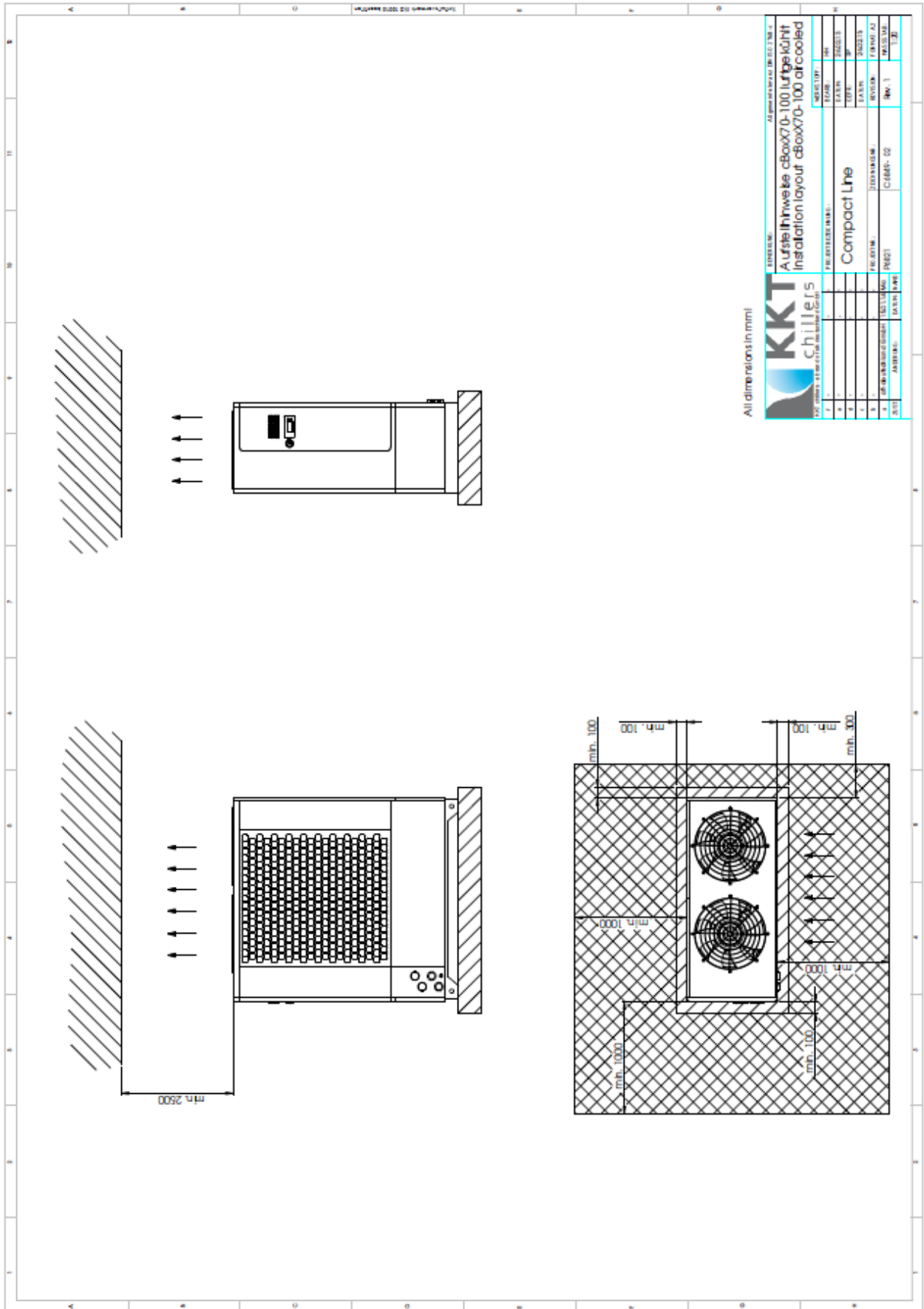

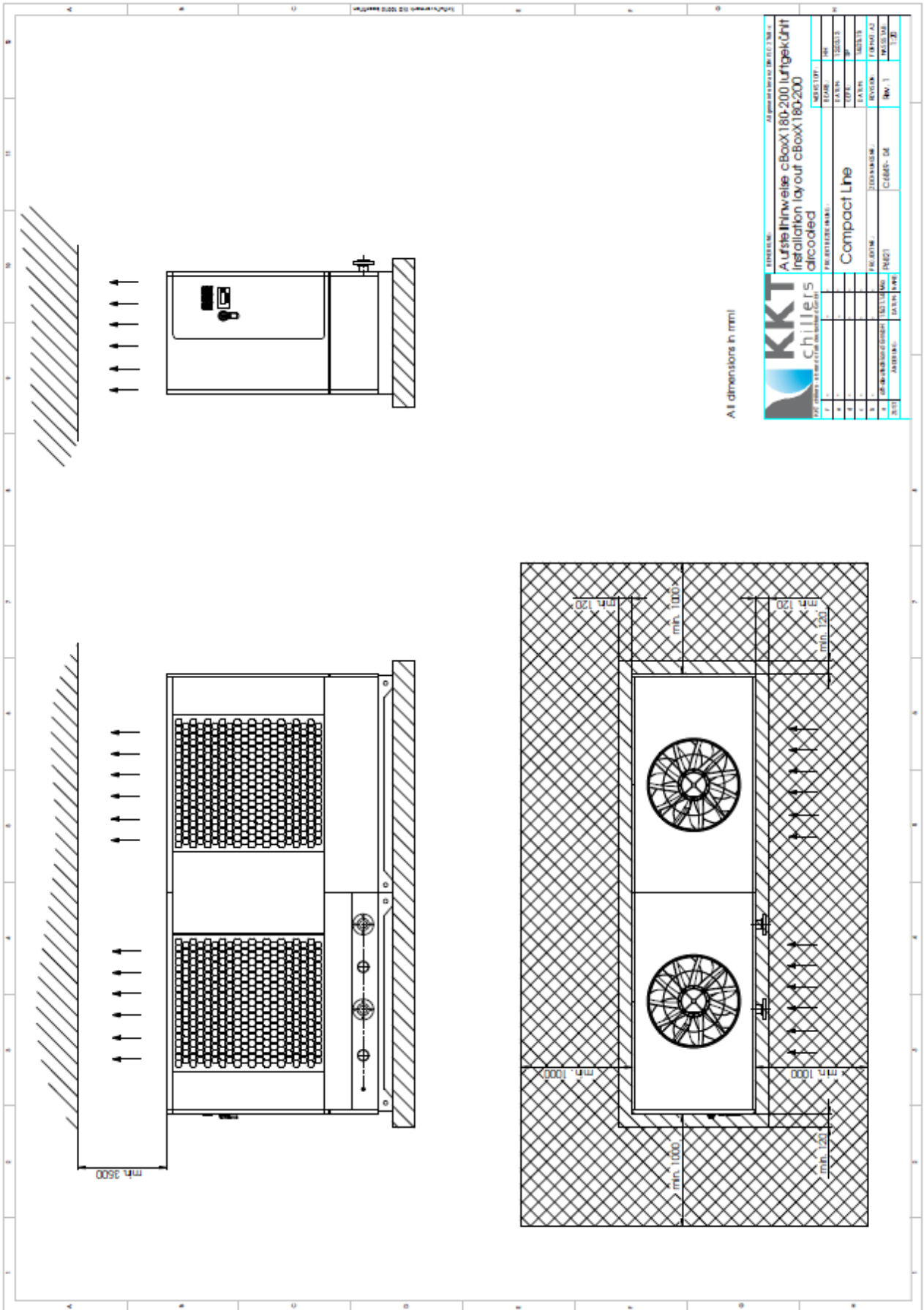

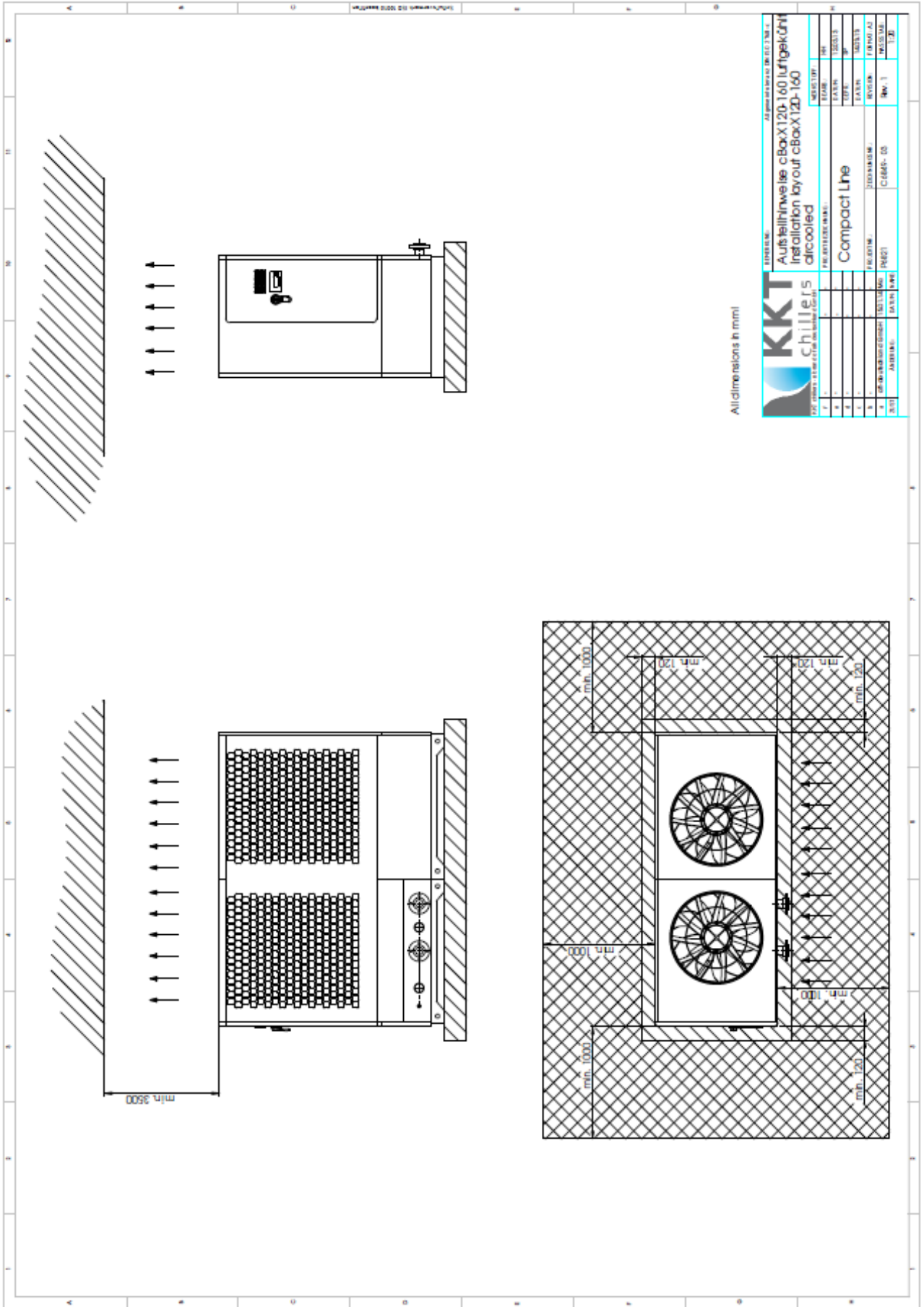



### III. Menu navigation

	<p><b>Attention::</b> The parameters specified here are given as an example only. Please refer to the parameter set included in the unit for the parameter settings that are relevant for your chiller.</p>
---	---

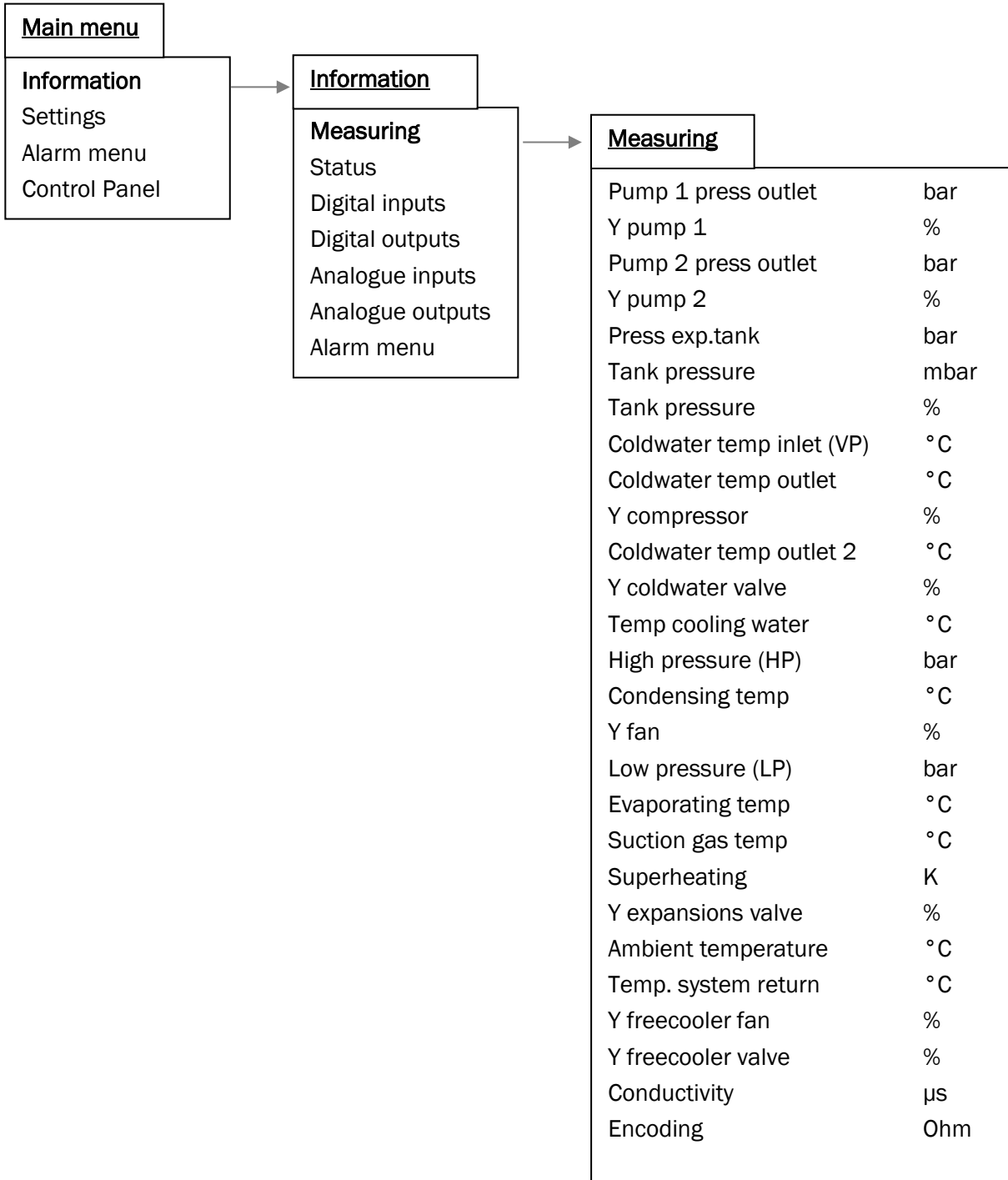

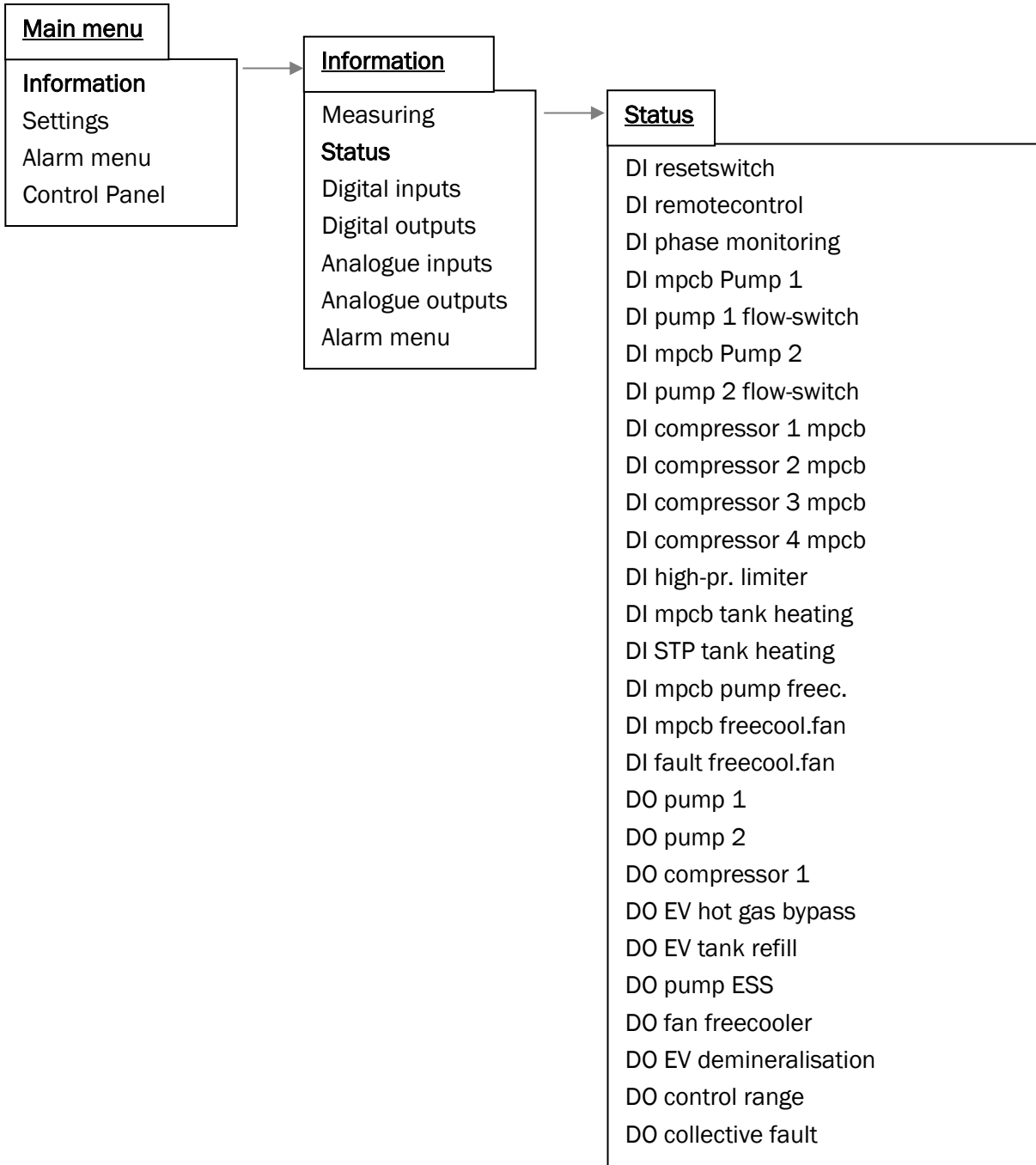

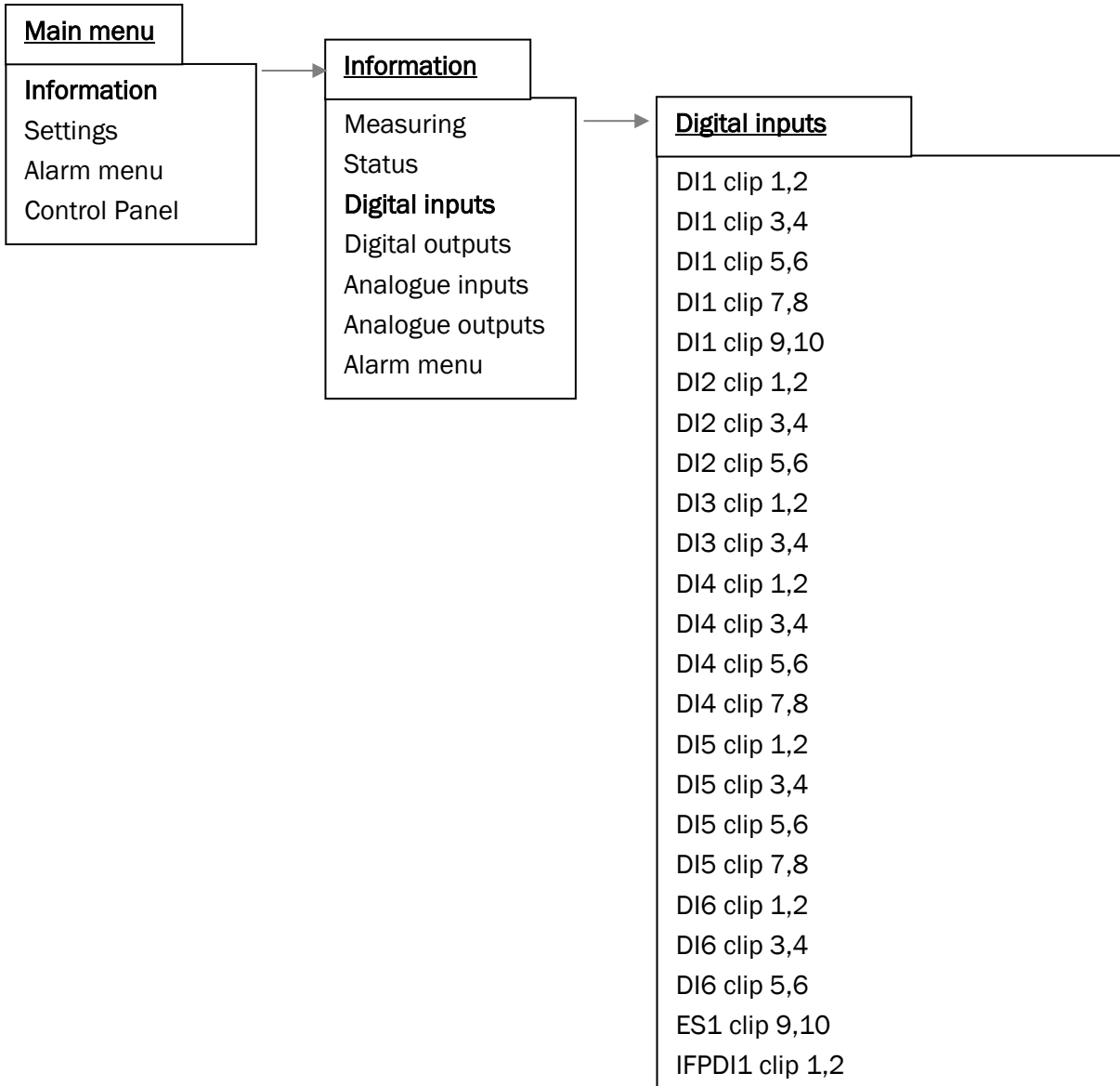

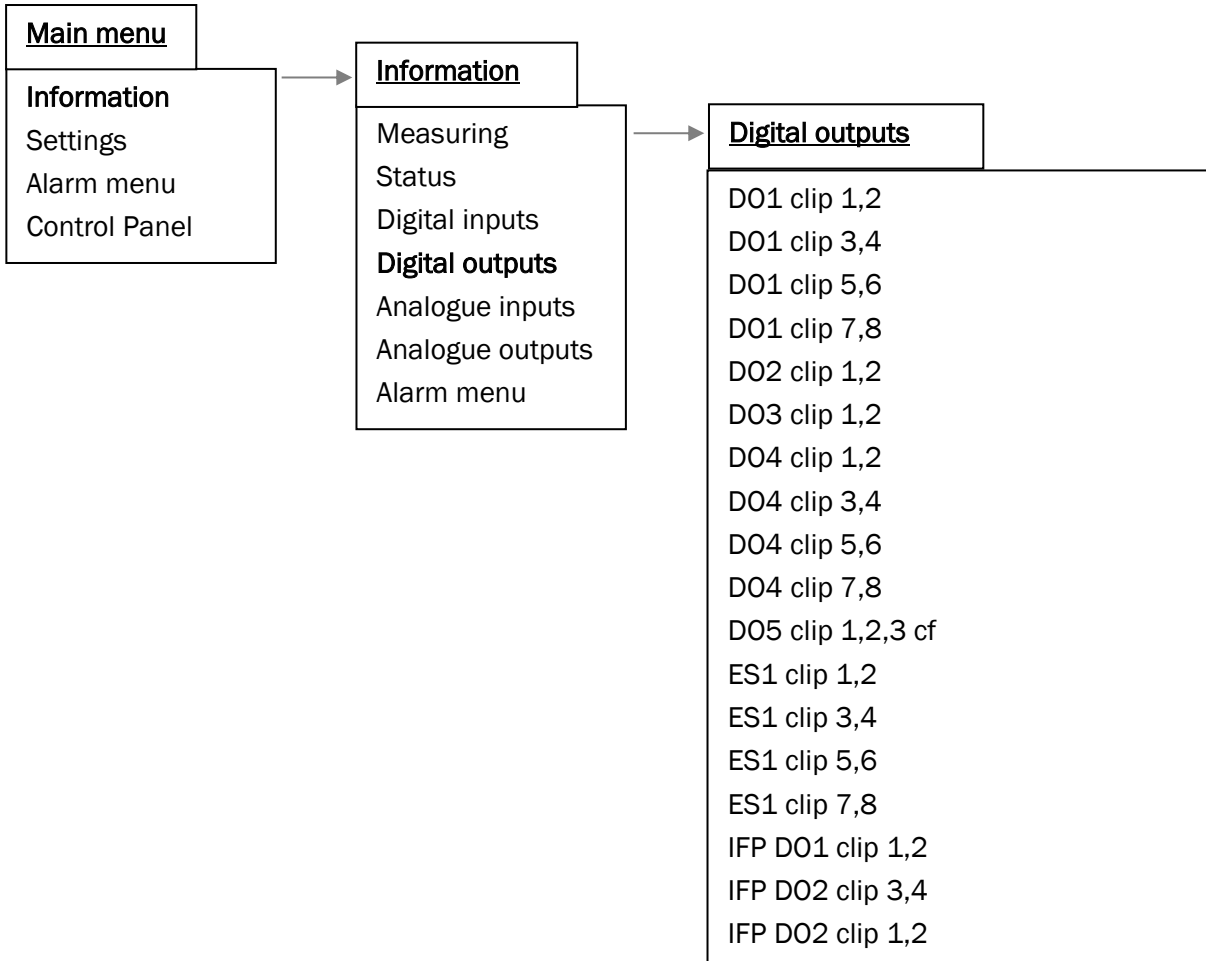

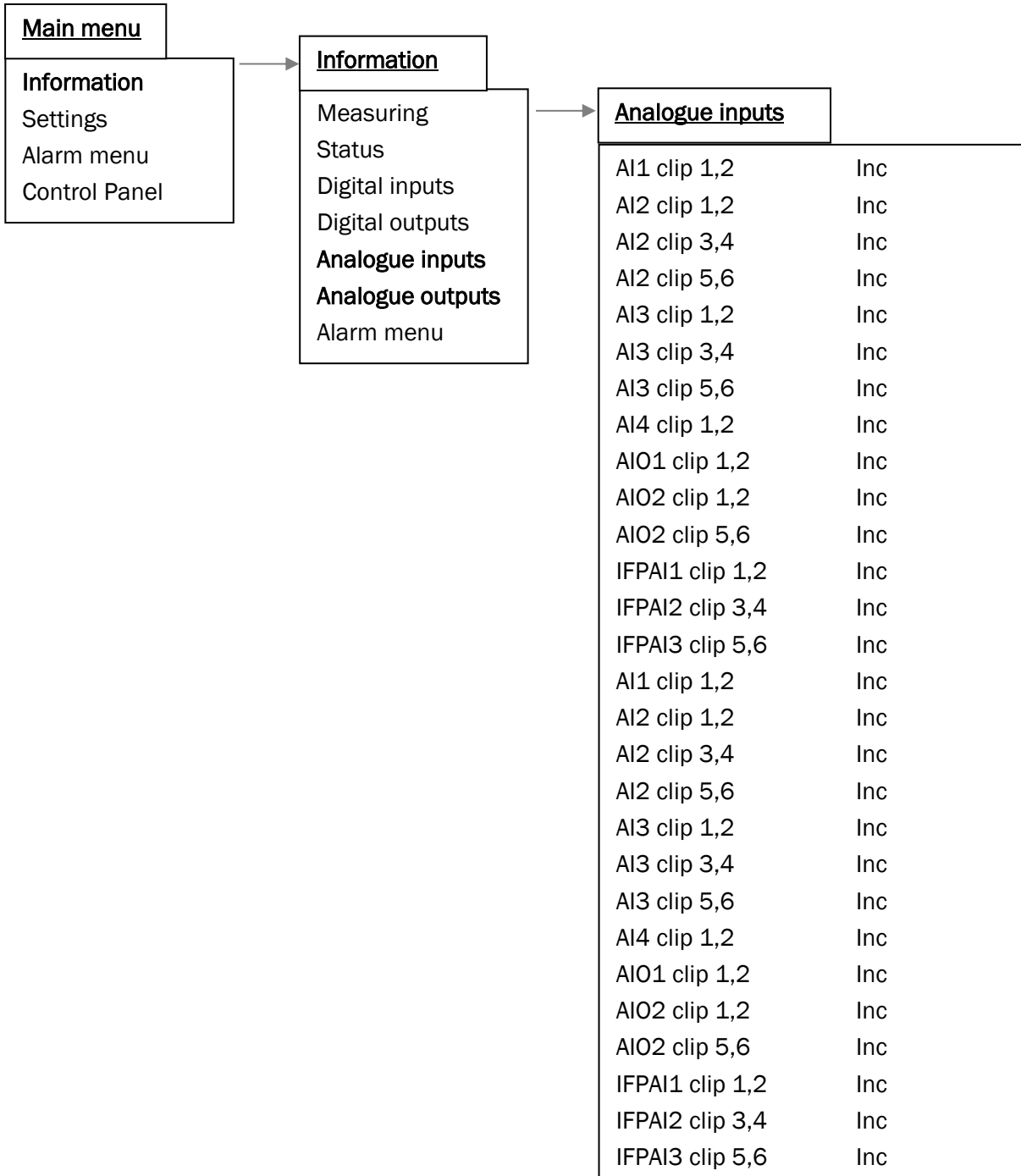

**Analogue inputs**

A01 clip 1,2	Inc
A01 clip 3,4	Inc
A01 clip 5,6	Inc
A01 clip 7,8	Inc
A02 clip 1,2	Inc
A02 clip 3,4	Inc
AIO1 clip 3,4	Inc
AIO2 clip 3,4	Inc

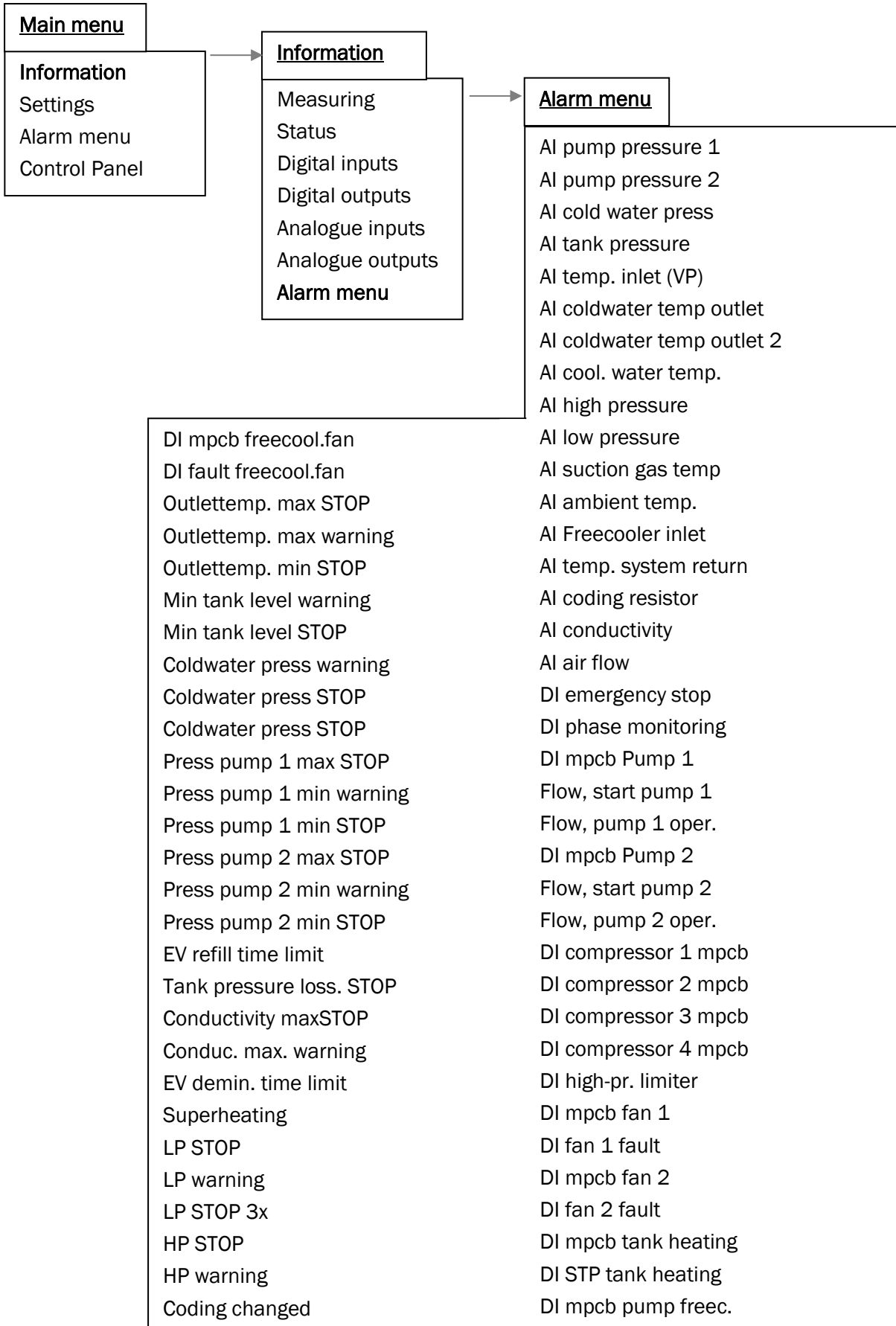

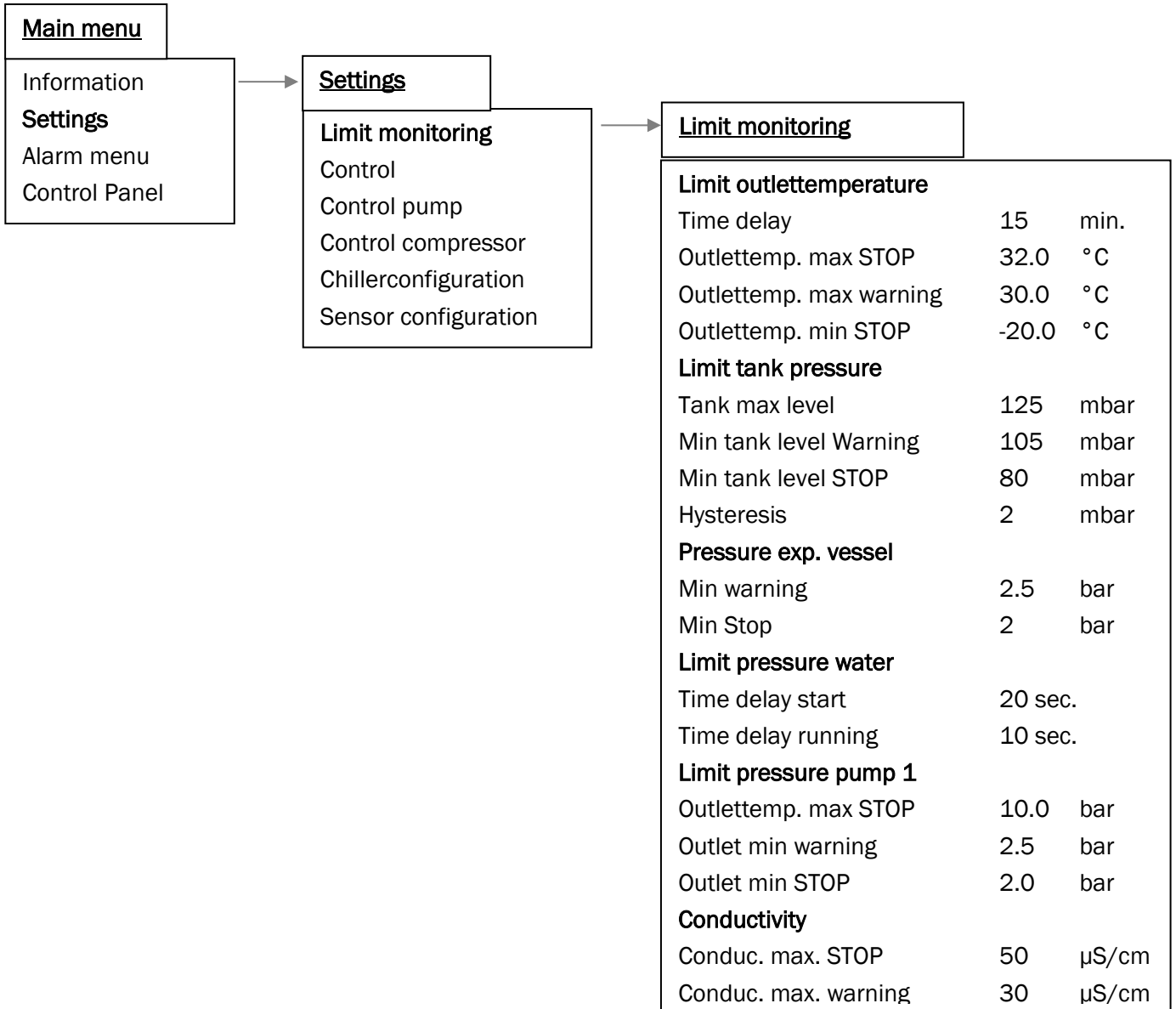

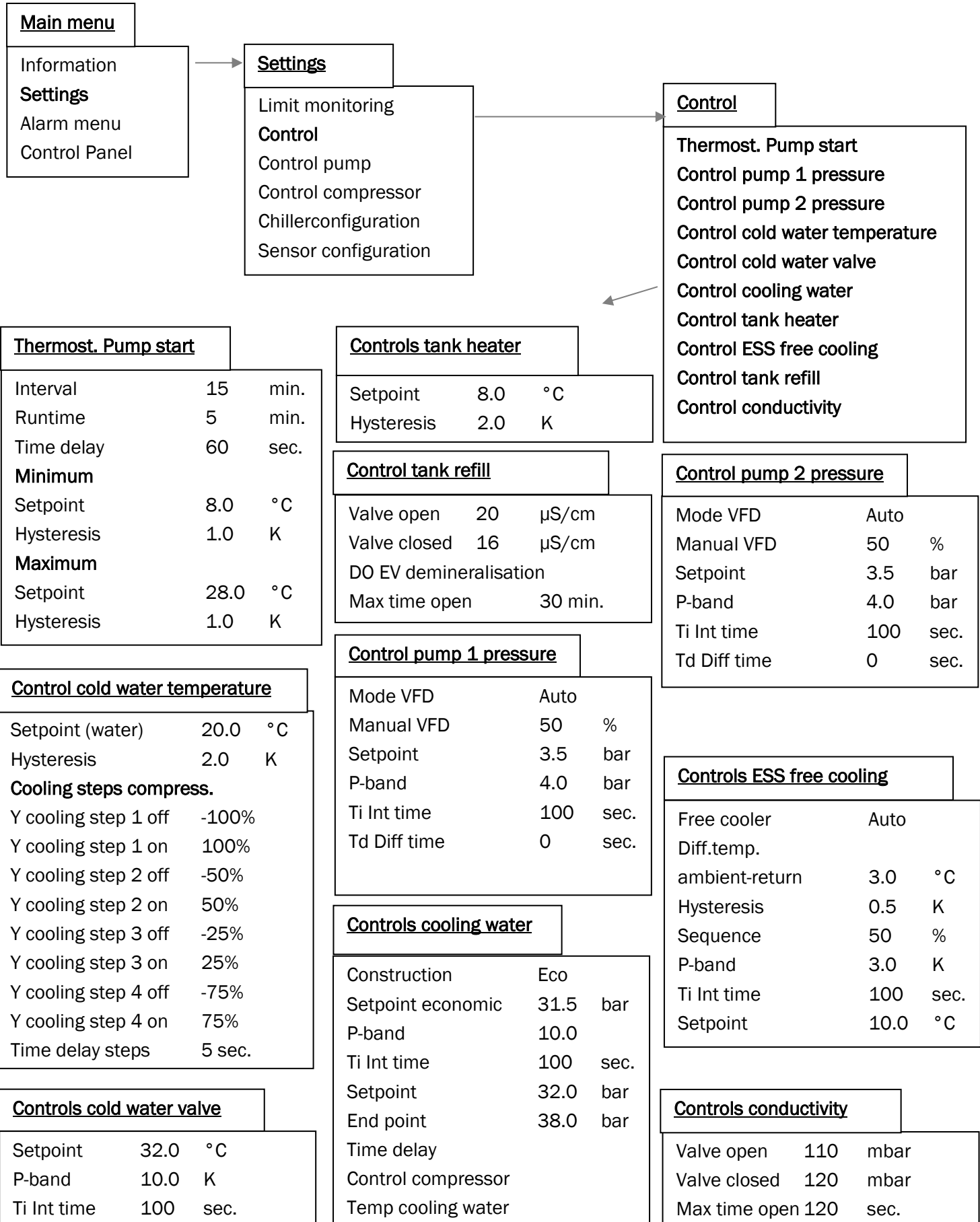



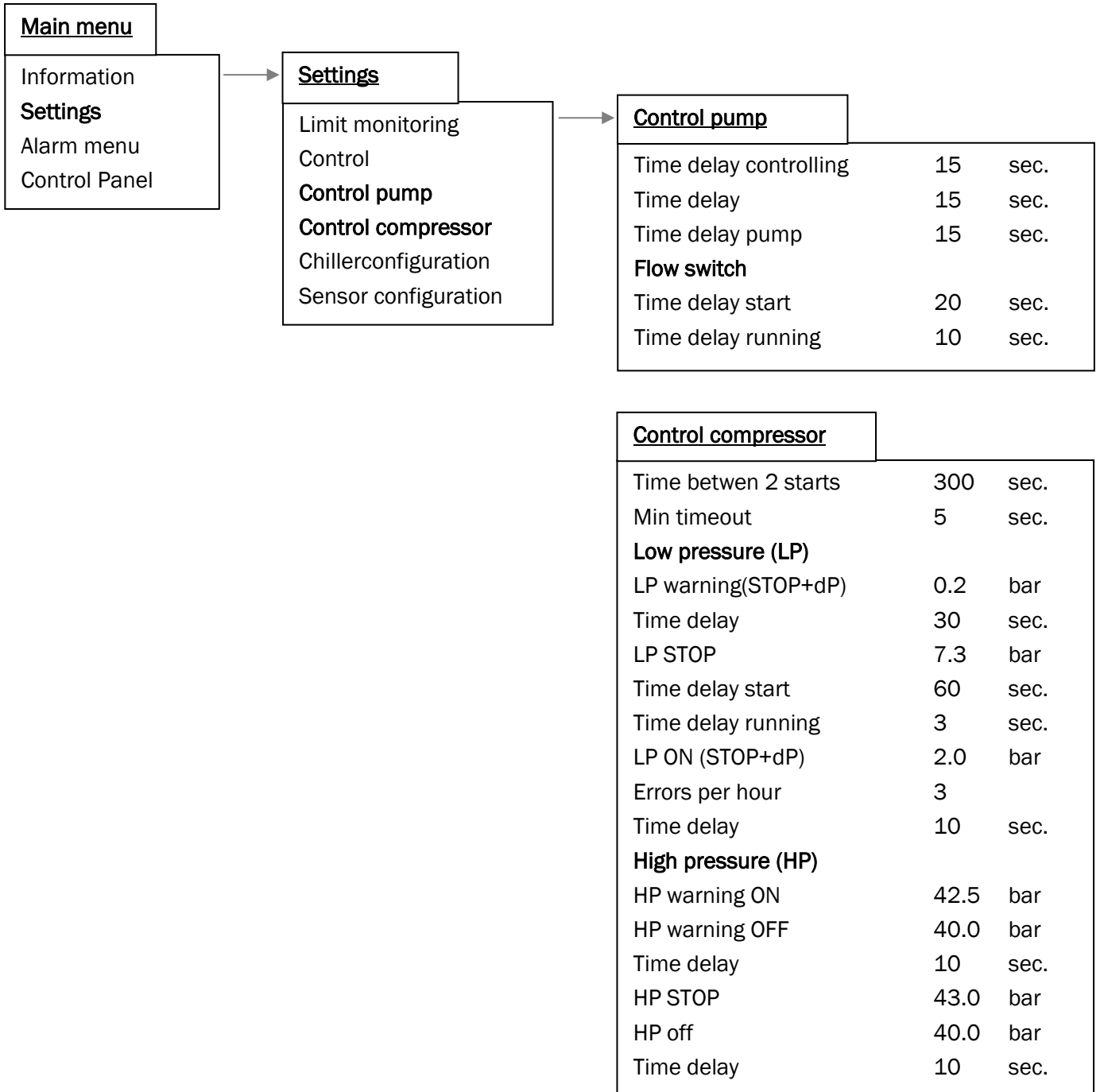

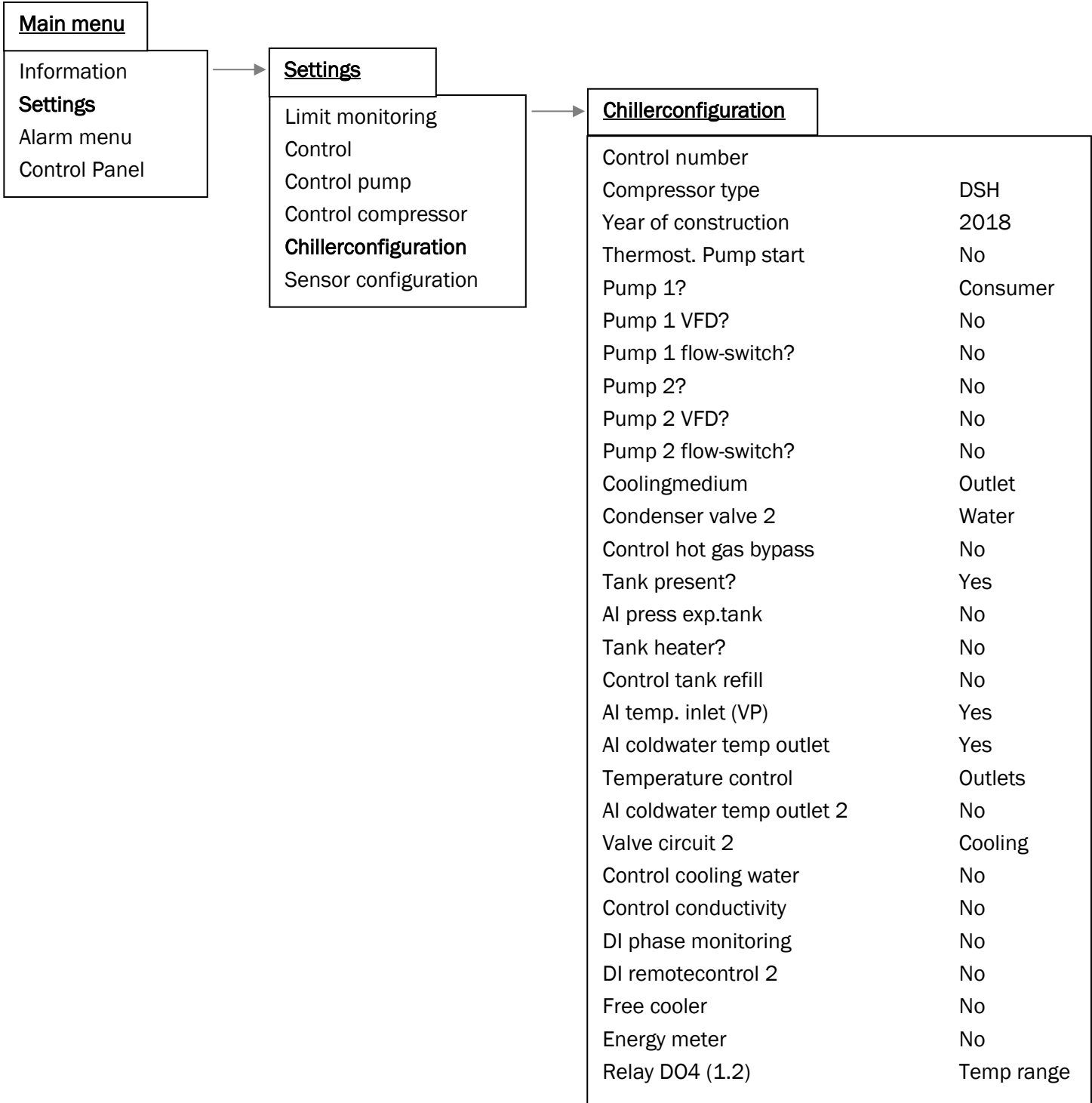

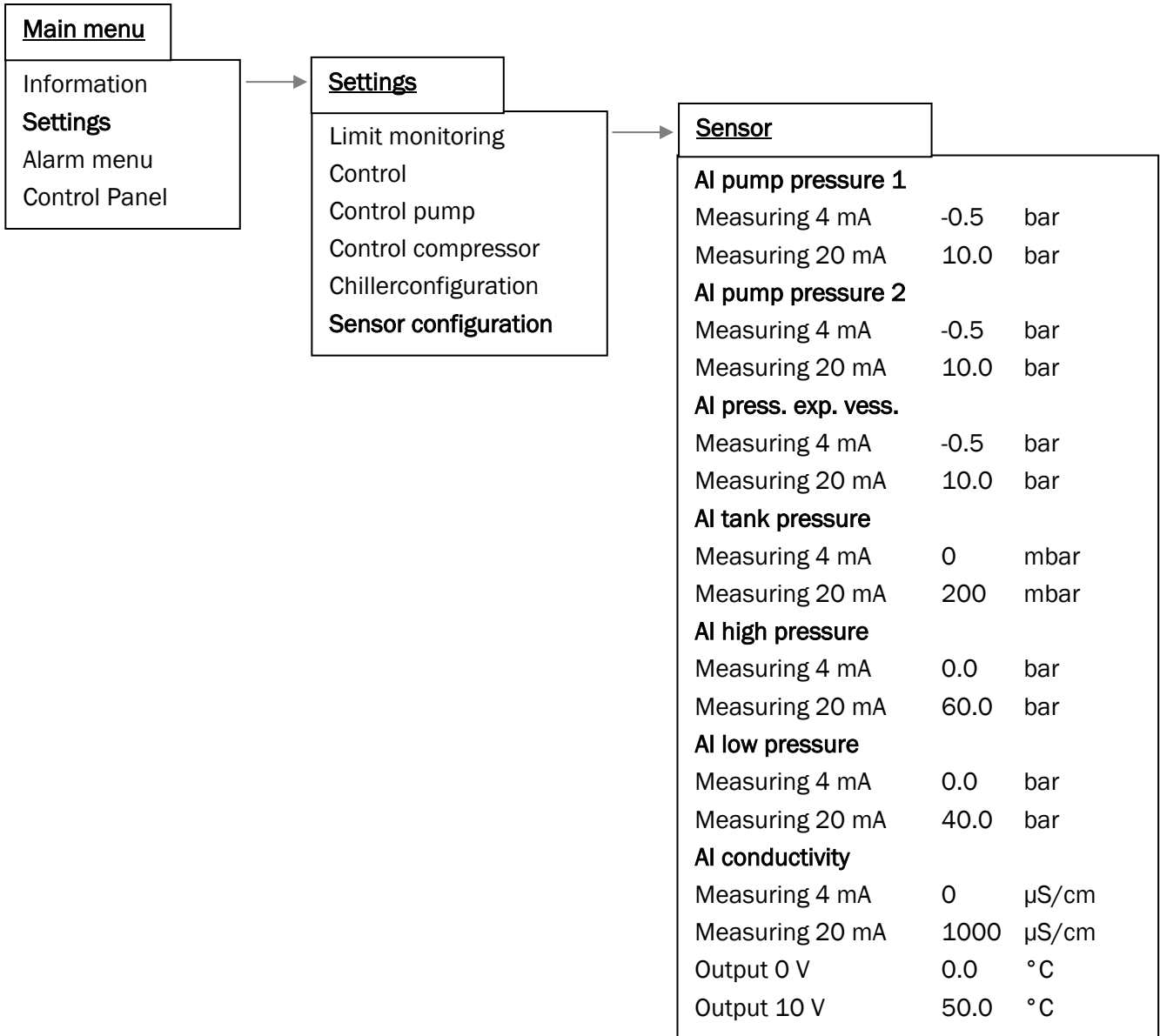



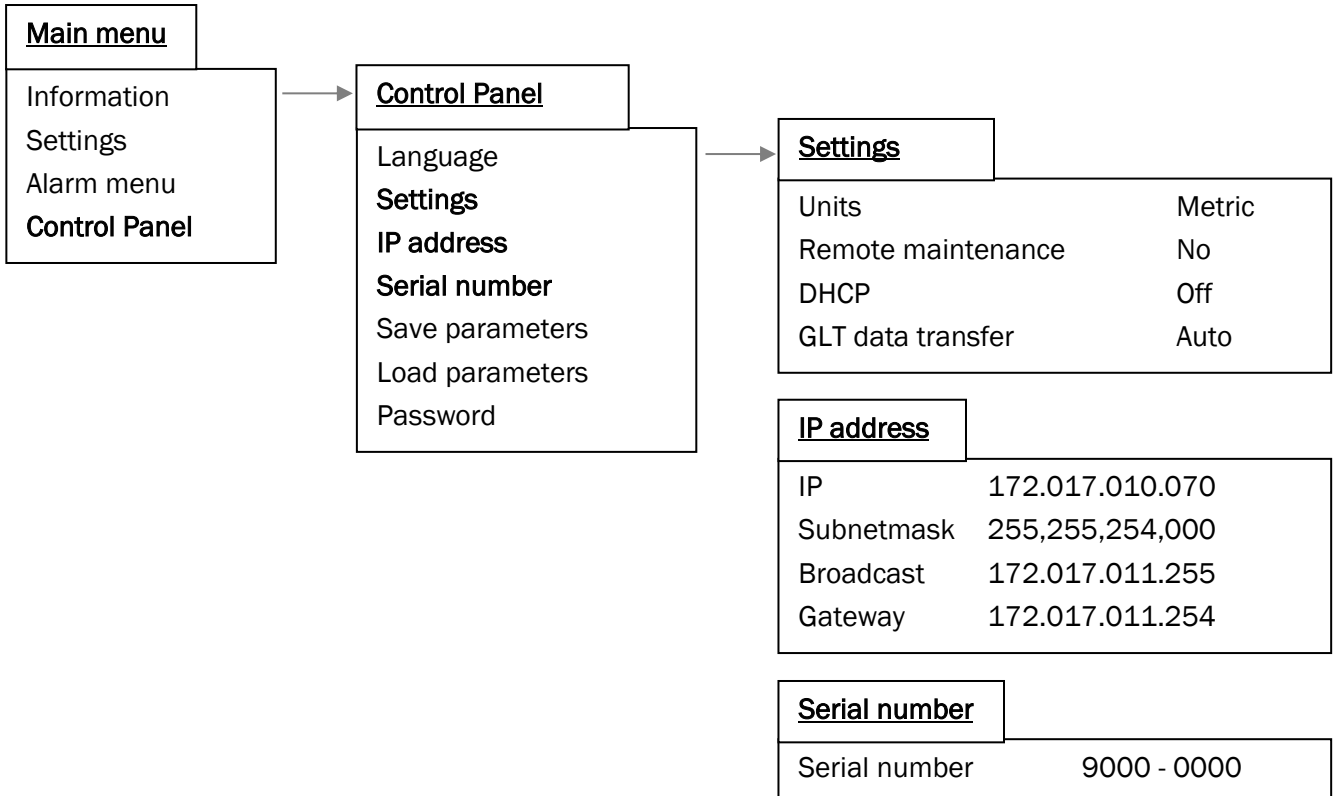

#### IV. Troubleshooting

Error code	Display view	Type of message	Message description	Cause of the message	Troubleshooting	Reaction of the chiller
111	HP warning	Group warning	Condensation pressure has exceeded the warning limit	Condensation pressure threatens to run against the design limit of the high pressure stop,	Clean the condenser and filter. Check the function of the fan. Check the cooling water circuit. Install the cover panels.	All components continue to run. (Warning - this is time-delayed from V. 2.60) Alarm is saved, manual reset. Attention: Reduction of the cooling level with a separate menu item without a message.
121	LP warning	Group warning	Evaporation pressure has fallen below the warning limit	Evaporating pressure approaches the low pressure stop limit, a compressor is switched off. (If the compressor count is greater than ONE)	Check liquid flow. Check the function of the expansion valve. Check the refrigerant level.	A compressor is switched off (from V. 2.60 time-delayed) and switches on again after pressure increase. All other components continue to run. Warning is not saved, automatischer reset .
131	Superheating	Collective warning message from Version 2.71 previously fault message AL171				
151	HP STOP	Group fault alarm	Condensation pressure is outside the allowable range.	Waste heat from the chiller circuit cannot be dissipated.	Clean the condenser and filter. Check the function of the fan. Check the cooling water circuit. Install the cover panels.	All compressors shut down. (time-delayed from V. 2.60) All other components continue to run. Alarm is saved. Manual reset.

161	LP STOP	Group fault alarm	Pressure has fallen below the minimum allowable pressure on the intake side of the compressor (low pressure side).	Liquid flow through the evaporator is too low. Refrigerant loss. Faulty function of the expansion valve. Faulty function of the LP sensor.	Check liquid flow. Check the function of the expansion valve. Check the refrigerant level.	After starting the compressor, the low pressure is bridged. Then all compressors switch off. When the pressure increases, the compressors switch on again. During operation, all compressors switch off with a time delay. They switch on again when the pressure increases. The compressors restart up to 3 times, after which alarm AL162 is triggered. All other components continue to run. Alarm is saved. Manual reset.
162	LP STOP 3x	Group fault alarm	The minimum permissible pressure on the suction side of the compressor (low pressure side) was 3 times lower.	S.h. LP STOP	S.h. LP STOP	Compressor no longer starts automatically after the 3rd low pressure STOP AL161, All other components continue to run. Alarm is saved. Manual reset.
171	Superheating	Collective fault message from Version 2.70 then warning WA131	The superheat design limit has been exceeded or not reached. vBoxX Min; cBoxX Min and Max.	Superheat too low or too high		only display if alarm occurred 3 times, Alarm is saved, 2x automatic reset, then manual reset.
301	Outlettemp. max warning	Group warning	The outlet temperature of the chiller circuit is approaching the upper design limit.	Thermal overload, No refrigeration.	Check refrigerating capacity, check the function of the refrigeration circuit	All components continue to run, Warning is saved, Manual reset.
312	Min tank level warning	Group warning	Level in the tank is approaching the minimum design limit.	Level in the tank is too low, level sensor in the tank is defective.	Fill tank, Check the function of the tank sensor in the tank	All components continue to run, Alarm is saved, Manual reset.

313	EV refill time limit	Group fault alarm	The solenoid valve of the tank refill does not close within the specified time.	The freshwater supply is interrupted.	Check the function of the solenoid valve tank refill. Open the shut-off devices integrated in the supply line. Check the supply line for leakage.	Solenoid valve for tank refill closes. All other components continue to run, Alarm is saved, Manual reset.
321	Coldwater press warning	Group warning	The liquid pressure at the evaporator is approaching the minimum or maximum limit	External slide is closed, Filter soiled, Air in the system.	Open external slide, Clean filter, Vent the system.	All components continue to run, Alarm is saved, Manual reset.
325	Measuring	Group warning	Pump intake pressure is below the set setpoint	Diaphragm expansion vessel defective Quantity of water in the closed pipe system is too low	Top-up water	All components continue to run, Alarm is saved, Manual reset.
326 327	Press pump 1 min warning Press pump 2 min warning	Group warning	The pump's pressure is approaching the minimum limit	Flow rate too high, chiller resistance too low, Air in the system	Reduce flow rate, increase chiller resistance, vent the system	All components continue to run, Alarm is saved, Manual reset.
331 334	Conduc. max. STOP Conduc. max. alarm	Group fault alarm	Conductivity exceeds maximum design limit.	Conductivity too high.	Check limit design value: If available: Check DI cartridge, Check flow through DI cartridge.	All components continue to run, Alarm is saved, Manual reset.
332	Conductivitymaxwarn.	Group warning	Conductivity is approaching maximum design limit.	Conductivity too high.	Check the limit default. If installed: Check DI cartridge, Check flow through DI cartridge.	All components continue to run, Alarm is saved, Manual reset.
333	EV demin. time limit	Group warning	The demineralization solenoid valve does not close within the specified time period.	DI cartridge worn. No flow through DI cartridge. Switch-off point set too high.	Replace DI cartridge. Check flow through the DI cartridge. DI cartridge worn.	Demineralization solenoid valve closes. All other components continue to run, Alarm is saved, Manual reset.



351	Outlettemp. max STOP	Group fault alarm	Maximum outlet temperature exceeded.	No refrigeration, Thermal overload.	Check function of the chiller circuit, Check installed heat load.	Chiller switches off immediately. Alarm is saved. Manual reset.
352	Outlettemp. min STOP	Group fault alarm	Outlet temperature is below the minimum.	Check function of the tank heater, check setpoint setting, ambient temperature too low.	Check tank heater function, check setpoint, increase ambient temperature.	Chiller switches off immediately, (Until V 2.60) (Compressors switch off immediately). Pumps deactivate via follow-up time, this would be correct) Alarm is saved, Manual reset.
361	Min tank level STOP	Group fault alarm	Level in tank is below the minimum.	Level in the tank is too low, Level sensor soiled or defective	Fill tank, Check the function of the tank sensor.	Chiller switches off immediately. Alarm is saved. Manual reset.
371	Coldwater press STOP	Group fault alarm	Cold water pressure at the evaporator is too low.	External slide is closed, Filter soiled, Air in the system.	Open external slide, Clean filter, Vent the system.	Compressors switch off immediately. Pump 1 & 2 consumer pump Pumps continue to run. Pump 1 = Consumer pump Pump 2 = Evaporator pump Pump 1 continues to run. Pump 2 switches off. Pump 1 = Consumer pump Pump 2 = Redundant The required pump continues to run. Alarm is saved. Manual reset.
378	Pr.exp.vess.max Stop	no message	Intake pressure of the pump is above the set setpoint	Diaphragm expansion vessel defective Quantity of water in the closed pipe system is too high	Exchange diaphragm expansion vessel Drain water / Readjust pressure	Shut down
379	Pr.exp.vess.min Stop	Group fault alarm	Pump intake pressure is below the set setpoint	Diaphragm expansion vessel defective Quantity of water in the closed pipe system is too low.	Top-up water	Chiller switches off immediately. Alarm is saved. Manual reset.

381 385	Press pump 1 max STOP Press pump 2 max STOP	Group fault alarm	Pressure of the liquid outlet pressure too high	External slide is closed, Filter soiled,	Open external gate valve, clean filter, check overflow valve setting	Pump switches off immediately. Alarm is saved. Manual reset.
382 386	Press pump 1 min STOP Press pump 2 min STOP	Group fault alarm	Pressure of the liquid outlet pressure too low	Flow rate too high, chiller resistance too low, Air in the system	Reduce flow rate, increase chiller resistance, vent the system	Pump switches off immediately. Alarm is saved. Manual reset.
501	AI temp. inlet (VP)	Collective warning message from Version 2.60	Sensor defective, sensor break or sensor short-circuit	Sensor defective, sensor break or sensor short-circuit	Check electrical connections of the sensor, check sensor using the characteristic curve	Alarm is saved, (From V.2.60) Manual reset.
502	AI coldwater temp outlet	Combined fault from Version 2.60	Sensor defective, sensor break or sensor short-circuit	Sensor defective, sensor break or sensor short-circuit	Check electrical connections of the sensor, check sensor using the characteristic curve	All components continue to run. If the temp. inlet sensor is functional, it is switched to this sensor and the setpoint is increased by 6K. Alarm is saved, (From V.2.60) Manual reset.
503	AI coldwater temp outlet 2	Combined fault from Version 2.60	Sensor defective, sensor break or sensor short-circuit	Sensor defective, sensor break or sensor short-circuit	Check electrical connections of the sensor, check sensor using the characteristic curve	Pump 1 and compressor continue to run, Cold water circuit 2 is blocked, Alarm is saved, (From V.2.60) Manual Reset.
504	AI temp. system return	Combined fault from Version 2.60	Sensor defective, sensor break or sensor short-circuit	Sensor defective, sensor break or sensor short-circuit	Check electrical connections of the sensor, check sensor using the characteristic curve	Free cooling is blocked. All other components continue to run, Alarm is saved, (From V.260) Manual reset.
505	AI ambient temp.	Combined fault from Version 2.60	Sensor defective, sensor break or sensor short-circuit	Sensor defective, sensor break or sensor short-circuit	Check electrical connections of the sensor, check sensor using the characteristic curve	Free cooling is blocked. All other components continue to run, Alarm is saved, (From V.260) Manual reset.

506	AI Freecooler inlet	Combined fault from Version 2.60	Sensor defective, sensor break or sensor short-circuit	Sensor defective, sensor break or sensor short-circuit	Check electrical connections of the sensor, check sensor using the characteristic curve	Free cooling is blocked. All other components continue to run, Alarm is saved, (From V.260) Manual reset.
511	AI cold water press	Combined fault from Version 2.60	Sensor defective, sensor break or sensor short-circuit	Sensor defective, sensor break or sensor short-circuit	Check electrical connections of the sensor, check sensor using the characteristic curve	Alarm is saved, (From V.2.60) Manual reset.
512	AI press. exp. vess.	Combined fault from Version 2.60	Sensor defective, sensor break or sensor short-circuit	Sensor defective, sensor break or sensor short-circuit	Check electrical connections of the sensor, check sensor using the characteristic curve	Alarm is saved, (From V.2.60) Manual reset.
513	AI pump pressure 1	Combined fault from Version 2.60	Sensor defective, sensor break or sensor short-circuit	Sensor defective, sensor break or sensor short-circuit	Check electrical connections of the sensor, check sensor using the characteristic curve	Pump 1 & 2 = Consumer pump - Pump 1 switches off, - Pump 2 and compressor continue to run. Pump 1 = Consumer pump Pump 2 = Evaporator pump Chiller switches off. Pump 1 = Consumer pump Pump 2 = Redundant - Pump 1 switches off, - Pump 2 switches on. Alarm is saved, (From V.2.60) Manual reset.

514	AI pump pressure 2	Combined fault from Version 2.60	Sensor defective, sensor break or sensor short-circuit	Sensor defective, sensor break or sensor short-circuit	Check electrical connections of the sensor, check sensor using the characteristic curve	Pump 1 & 2 = Consumer pump - Pump 2 switches off, - Pump 1 and compressor continue to run. Pump 1 = Consumer pump Pump 2 = Evaporator pump Alarm is not recognised, No reaction up to V 2.58 - Pump 2 and compressor switch off, - Pump 1 runs up to outlet temperature Max Stop continues. From V. 260 Pump 2 = Consumer pump Pump 1 = Redundant - Pump 2 switches off, - Pump 1 switches on. Alarm is saved, (From V.2.60) Manual reset.
515	AI tank pressure	Combined fault from Version 2.60	Sensor defective, sensor break or sensor short-circuit	Sensor defective, sensor break or sensor short-circuit	Check electrical connections of the sensor, check sensor using the characteristic curve	Chiller switches off immediately, Alarm is saved, (From V.2.60) Manual reset.
521	AI high pressure	Combined fault from Version 2.60	Sensor defective, sensor break or sensor short-circuit	Sensor defective, sensor break or sensor short-circuit	Check electrical connections of the sensor, check sensor using the characteristic curve	Pumps continue to run, Alarm is saved, (From V.260) Manual reset.
522	AI low pressure	Combined fault from Version 2.60	Sensor defective, sensor break or sensor short-circuit	Sensor defective, sensor break or sensor short-circuit	Check electrical connections of the sensor, check sensor using the characteristic curve	Pumps continue to run, Compressor (KK) stops immediately Alarm is saved, (From V.260) Manual reset.
523	AI suction gas temp	Combined fault from Version 2.60	Sensor defective, sensor break or sensor short-circuit	Sensor defective, sensor break or sensor short-circuit	Check electrical connections of the sensor, check sensor using the characteristic curve	Pumps continue to run, Compressor (KK) stops immediately Alarm is saved, (From V.260) Manual reset.

526	AI cool. water temp.	Combined fault from Version 2.60	Sensor defective, sensor break or sensor short-circuit	Sensor defective, sensor break or sensor short-circuit	Check electrical connections of the sensor, check sensor using the characteristic curve	Cooling water circuit is blocked. Refrigeration circuit goes to high pressure fault. Alarm is saved, (From V.2.60) Manual reset.
531	AI conductivity	Combined fault from Version 2.60	Sensor defective, sensor break or sensor short-circuit	Sensor defective, sensor break or sensor short-circuit	Check electrical connections of the sensor, check sensor using the characteristic curve	all components continue to run EV demineralization closes. Alarm is saved, (From V.2.60) Manual reset.
591	AI coding resistor	not in collective fault, omitted from Version 2.60	Coding resistor is missing	Coding resistor is missing	Check coding resistor	Chiller only continues to run with one compressor. Manual rest. (Up to V. 2.59)
592	Coding changed	Collective fault, omitted from Version 2.60	Coding error	The coding resistor measures a different encoding since the last switch-on (number of compressors)	Coding resistor defective, not connected, check the contact	Chiller only continues to run with one compressor. Alarm is saved. Manual reset. (Up to V. 259)
602	DI phase monitoring	Combined fault from Version 2.60	Phase monitoring has tripped	Error in relation to phase sequence, phase failure, undervoltage and asymmetry	Check feed	Chiller switches off immediately. Alarm is saved, (From V.2.60) Manual reset.
611	DI mpcb Pump 1	Group fault alarm	Motor protection switch has tripped	Motor current above the permissible range, Motor runs only on two phases, direction of rotation, poor contact at clip points, Winding fault, earth fault, rotor blocked.	Check the motor power consumption, check the operating point, check the electrical connection of the components	Pump 1 & 2 = Consumer pump - Pump 1 switches off, - Pump 2 and compressor continue to run. Pump 1 = Consumer pump Pump 2 = Evaporator pump Chiller switches off. Pump 1 = Consumer pump Pump 2 = Redundant - Pump 1 switches off, - Pump 2 switches on. Manual reset, Alarm is saved.

613	Flow, start pump 1	Group fault alarm	Flow switch did not switch through after the pump start-up phase	Flow too low	Check flow, check shut-off valves, check pump, check the setting of the reed contact at the flow monitor	<p>Pump 1 &amp; 2 = Consumer pump</p> <ul style="list-style-type: none"> <li>- Pump 1 switches off,</li> <li>- Pump 2 and compressor continue to run.</li> </ul> <p>Pump 1 = Consumer pump  Pump 2 = Evaporator pump  Chiller switches off.</p> <p>Pump 1 = Consumer pump  Pump 2 = Redundant</p> <ul style="list-style-type: none"> <li>- Pump 1 switches off,</li> <li>- Pump 2 switches on.</li> </ul> <p>Manual reset,  Alarm is saved.</p>
614	Flow, pump 1 oper.	Group fault alarm	Flow switch did not switch through during the pump operating phase	Flow too low	Check flow, check shut-off valves, check the setting of the reed contact at the flow monitor	<p>Pump 1 &amp; 2 = Consumer pump</p> <ul style="list-style-type: none"> <li>- Pump 1 switches off,</li> <li>- Pump 2 and compressor continue to run.</li> </ul> <p>Pump 1 = Consumer pump  Pump 2 = Evaporator pump  Chiller switches off.</p> <p>Pump 1 = Consumer pump  Pump 2 = Redundant</p> <ul style="list-style-type: none"> <li>- Pump 1 switches off,</li> <li>- Pump 2 switches on.</li> </ul> <p>Manual reset,  Alarm is saved.</p>

615	DI mpcb Pump 2	Group fault alarm	Motor protection switch has tripped	Motor current above the permissible range, Motor runs only on two phases, direction of rotation, poor contact at clip points, Winding fault, earth fault, rotor blocked.	Check the motor power consumption, check the operating point, check the electrical connection of the components	<p>Pump 1 &amp; 2 = Consumer pump</p> <ul style="list-style-type: none"> <li>- Pump 2 switches off,</li> <li>- Pump 1 and compressor continue to run.</li> </ul> <p>Pump 1 = Consumer pump Pump 2 = Evaporator pump</p> <ul style="list-style-type: none"> <li>- Pump 2 and compressor switch off,</li> <li>- Pump 1 runs up to outlet temperature</li> </ul> <p>Max Stop continues.</p> <p>Pump 2 = Consumer pump Pump 1 = Redundant</p> <ul style="list-style-type: none"> <li>- Pump 2 switches off,</li> <li>- Pump 1 switches on.</li> </ul> <p>Manual reset, Alarm is saved.</p>
617	Flow, start pump 2	Group fault alarm	Flow switch did not switch through after the pump start-up phase	Flow too low	Check flow, check shut-off valves, check pump, check the setting of the reed contact at the flow monitor	<p>Pump 1 &amp; 2 = Consumer pump</p> <ul style="list-style-type: none"> <li>- Pump 2 switches off,</li> <li>- Pump 1 and compressor continue to run.</li> </ul> <p>Pump 1 = Consumer pump Pump 2 = Evaporator pump</p> <ul style="list-style-type: none"> <li>- Pump 2 and compressor switch off,</li> <li>- Pump 1 runs up to outlet temperature</li> </ul> <p>Max Stop continues.</p> <p>Pump 2 = Consumer pump Pump 1 = Redundant</p> <ul style="list-style-type: none"> <li>- Pump 2 switches off,</li> <li>- Pump 1 switches on.</li> </ul> <p>Manual reset, Alarm is saved.</p>

618	Flow, pump 2 oper.	Group fault alarm	Flow switch did not switch through during the pump operating phase	Flow too low	Check flow, check shut-off valves, check the setting of the reed contact at the flow monitor	<p>Pump 1 &amp; 2 = Consumer pump</p> <ul style="list-style-type: none"> <li>- Pump 2 switches off,</li> <li>- Pump 1 and compressor continue to run.</li> </ul> <p>Pump 1 = Consumer pump Pump 2 = Evaporator pump</p> <ul style="list-style-type: none"> <li>- Pump 2 and compressor switch off,</li> <li>- Pump 1 runs up to outlet temperature</li> </ul> <p>Max Stop continues.</p> <p>Pump 2 = Consumer pump Pump 1 = Redundant</p> <ul style="list-style-type: none"> <li>- Pump 2 switches off,</li> <li>- Pump 1 switches on.</li> </ul> <p>Manual reset, Alarm is saved.</p>
619	DI mpcb pump freec.	Group fault alarm	Motor protection switch has tripped	Motor current above the permissible range, Motor runs only on two phases, direction of rotation, poor contact at clip points, Winding fault, earth fault, rotor blocked.	Check the motor power consumption, check the operating point, check the electrical connection of the components	<p>all components continue to run</p> <p>Free cooling is stopped</p> <p>Fault is stored and must be reset manually</p>
621 622 623 624	DI compressor 1 mpcb DI compressor 2 mpcb DI compressor 3 mpcb DI compressor 4 mpcb	Group fault alarm	Motor protection switch has tripped	Motor current above the permissible range, Motor runs only on two phases, direction of rotation, poor contact at clip points, Winding fault, earth fault, rotor blocked.	Check the motor power consumption, check the operating point, check the electrical connection of the components	<p>Pumps continue to run</p> <p>the faulty compressor (KK) stops immediately</p> <p>the other compressors continue to run</p> <p>Fault is stored and must be reset manually</p>



627	DI high-pr. limiter	Group fault alarm	High-pressure limiter has tripped.	Unable to remove the waste heat of the refrigeration circuit.	Clean the condenser and filter. Check the function of the fan. Check the cooling water circuit. Install the cover panels. Press the Reset button and acknowledge at the display.	Pumps continue to run, Compressor (KK) stops immediately. Fault is stored and must be reset manually
631 633 635	DI mpcb fan 1 DI mpcb fan 2 DI mpcb freecool.fan	Group fault alarm	Motor protection switch has tripped	Motor current above the permissible range, Motor runs only on two phases, direction of rotation, poor contact at clip points, Winding fault, earth fault, rotor blocked.	Check the motor power consumption, Check the operating point, check the electrical connection of the components	Pump and compressor continue to run. Compressor switches off via HP. Fault is stored and must be reset manually
632 634 636	DI fan 1 fault DI fan 2 fault DI fault fan ESS	Group fault alarm	Internal monitoring of the fan has tripped.	Motor runs only on two phases, direction of rotation, poor contact at clip points, Winding fault, earth fault, rotor blocked.	Check the motor power consumption, check the electrical connection of the components, check for mechanical blocking,	Pump and compressor continue to run. Compressor switches off via HP. Fault is stored and must be reset manually.
641 643	DI mpcb tank heating	Group fault alarm	Circuit breaker has tripped.	Current above the permissible range, poor contact at clip points due to soiling or corrosion, Short-circuit between the heating rods, earth fault.	Check the electrical connection to the components, test for short to earth	all components continue to run. Tank heater is deactivated. Fault is stored and must be reset manually
642 644	DI STP tank heating	Group fault alarm	Safety temperature limiter of the tank heating has tripped	Tank temperature is too high, no water in tank, Trigger point of STP incorrectly set.	Check the tank temperature, check the level, check the tripping point of the STP	all components continue to run. Tank heater is deactivated. Fault is stored and must be reset manually



**Attention: Make sure that the cause of the fault has been eliminated before resetting fault messages. Frequent resetting of fault messages without rectifying the cause can cause permanent damage to the system!**

V. Maintenance intervals in accordance with the VDMA

	Explanation	Annual	Six-monthly	As required	Remark
	<b>Compressor</b>				
1	Optical check for dirt, damage and corrosion	x		x	
2	Check fixing, check running noises	x			
3	Measure the intake pressure	x			
4	Measure the suction gas temperature upstream of the compressor	x			
5	Measure the compression end temperature at the discharge port	x			
6	Check the oil level	x			
7	Check the acid content of the oil (acid test)			x	
8	Oil change			x	
9	Check that the crankcase heater is working	x			
10	Check that the output control is working	x			
11	Check the refrigerant side for leaks	x			
12	Check high/low pressure switching equipment	x			
	<b>Air-cooled condenser</b>				
20	Optical check for dirt, damage and corrosion	x		x	
21	Measure the condensing temperature	x			
22	Measure the refrigerant side supercooling temperature at the condenser outlet	x			
23	Measure the medium temperature at condenser inlet and outlet	x			
24	Check that the condensation pressure control is functioning properly	x			
25	Check the refrigerant side for leaks	x			
	<b>Evaporator</b>				
30	Optical check for dirt, damage and corrosion	x			
31	Measure refrigerant overheating temperature	x			
32	Measure the medium temperature at the evaporator inlet and outlet	x			
33	Measure the anti-freeze temperature (freezing point) of the heat transfer media	x			
34	Check the water and refrigerant side for leaks	x			

	Explanation	Annual	Six-monthly	as required	Remark
	<b>Parts in the refrigeration circuit/water circuit</b>				
40	Optical check for dirt, damage and corrosion	x	x		
41	Check insulation for damage	x			
42	Check filter dryer for blockage	x			
43	Replace filter dryer			X	If components in the refrigeration circuit are replaced
45	Check all pipes carrying refrigerant for corrosion and damage	x			
	<b>Fans</b>				
50	Optical check for dirt, damage and corrosion	x		x	
51	Check fixings and bearings	x			
52	Check flexible connection for tightness (electrical connection)	x			
	<b>Pump and piping</b>				
60	Optical check for dirt, damage and corrosion	x			
61	Check fixing parts and bearings	x			
62	Check the safety function of the safety switching devices	x			
63	Check pump/mechanical seal for leaks	x		x	
	<b>Water filters</b>				
70	Optical check for dirt, damage and corrosion	x		x	
71	Clean filters	x		x	
72	Check filters for damage	x			

No.:	Explanation	Annual	Six-monthly	as required	Remark
	<b>Tank / water tank</b>				
80	Optical check for dirt, damage and corrosion	x			
81	Check fixing	x			
82	Check level	x			
	<b>Control cabinet</b>				
90	Optical check for dirt, damage and corrosion	x		x	
91	Check fixing	x			
92	Check all threaded connections	x			
93	Check all indicator lights and error messages	x			
94	Check the temperature and pressure sensors are functioning properly	x			
95	Check the function of the motor protection switches	x			
96	Check 24 VDC and supply voltage	x		x	
97	Check control cabinet heater	x			
99	Check control cabinet filter and if necessary replace/clean	x			
	<b>Documents and labelling</b>				
110	All documents such as operating instructions, diagrams, circuit plans, system log are present	x		x	
111	Rating plate and labels are clearly legible	x		x	
	<b>Battery - time/date</b>				
120	Battery			x	Every 5 years
	<b>Leakage control of the refrigeration circuit in accordance with (EC) 517/2014</b>	x			

## VI. Product Registration

<https://www.kkt-chillers-service.de/produktregistrierung.html>

## VII. EC Declaration of Conformity

EG-Konformitätserklärung  
EC declaration of conformity  
Déclaration de conformité CE



<b>Gerät</b> (machine; machine):	Industriekühler (Industrial Chiller, Refroidisseur industriel)
<b>Maschinentyp</b> (type; type):	Alle Modelle der Baureihen (All models of the series; Tous les modèles des séries) cBoxX 30, cBoxX 40, cBoxX 50, cBoxX 60, cBoxX 70, cBoxX 80, cBoxX 90, cBoxX 100, cBoxX 120, cBoxX 160, cBoxX 180, cBoxX 200
<b>Zur bestimmungsgemäßen Verwendung als</b> (usage; utilisation):	Prozesskühler (Process Water Chiller, Refroidisseur de processus) Luftgekühlt (air cooled, refroidi par air), Wassergekühlt (water cooled, refroidi par l'eau)
<b>Seriennummer</b> (serial number, numéro de série)	9xxx2500 – 9xxx4000 (xxx=030,040...100,120...200)
<b>Erklärung</b> (description, explication)	xxx= Maschinentyp (type; type), 2500-3000= Seriennummer (serial number, numéro de série)

Hiermit erklären wir die Konformität des Gerätes im Sinne folgender Richtlinien und Normen.

Herewith we declare the conformity of the machine according to following instructions and standards.

Par la présente, nous déclarons que cette machine satisfait les dispositions suivantes.

<b>Richtlinie</b> (instruction; directives):	Maschinenrichtlinie 2006/42/EG (EC machinery directive, Directives CEE relatives aux machines) Druckgeräterichtlinie 2014/68/EU (PED; Directives CEE relatives aux pressions) Niederspannungsrichtlinie 2014/35/EU (Low voltage instructions, Directives CEE relatives aux basses tensions) Elektromagnetische Verträglichkeit 2014/30/EU (EMV-instructions, Compatibilité électromagnétique) RoHS 2011/65/EU (Restriction of certain Hazardous Substances, restriction de l'utilisation de certaines substances) 2009/125/EG Ökodesignrichtlinie (Directive ecodesign)
<b>Angewandte harmonisierte Normen</b> (applied harmonized standards; normes harmonisées utilisées):	DIN EN 60204-1:2019-06 DIN EN 61000-3-2:2017-03 DIN EN 61000-3-3:2014-03 DIN EN ISO 13857:2008-06 EN ISO 12100:2011-03 EN 378
<b>Angewandtes Konformitätsbewertungsverfahren</b> (used EG-conformity-module; module de conformité):	Modul A2 der Druckgeräterichtlinie 2014/68/EU für alle oben genannten Modelle (Modul A2 - for all models above, pour tous les modèles):
<b>benannte Stelle</b> (Notified Bodies; autorité, corps notifiés):	TÜV SÜD Industrie Service GmbH Westendstr. 199 80686 München CE Kenn-Nr.: 0036
<b>Verantwortlicher des Herstellers</b> (person responsible of the manufacturer; responsable chez le fabricant):	 Leiter Entwicklung Kühlung Markus Zobler Gültigkeit/Valid/Valable: 2019-2020
Kasendorf, 2019-Nov-11	